

START-UP COMMERCIAL DIRECT-FIRED

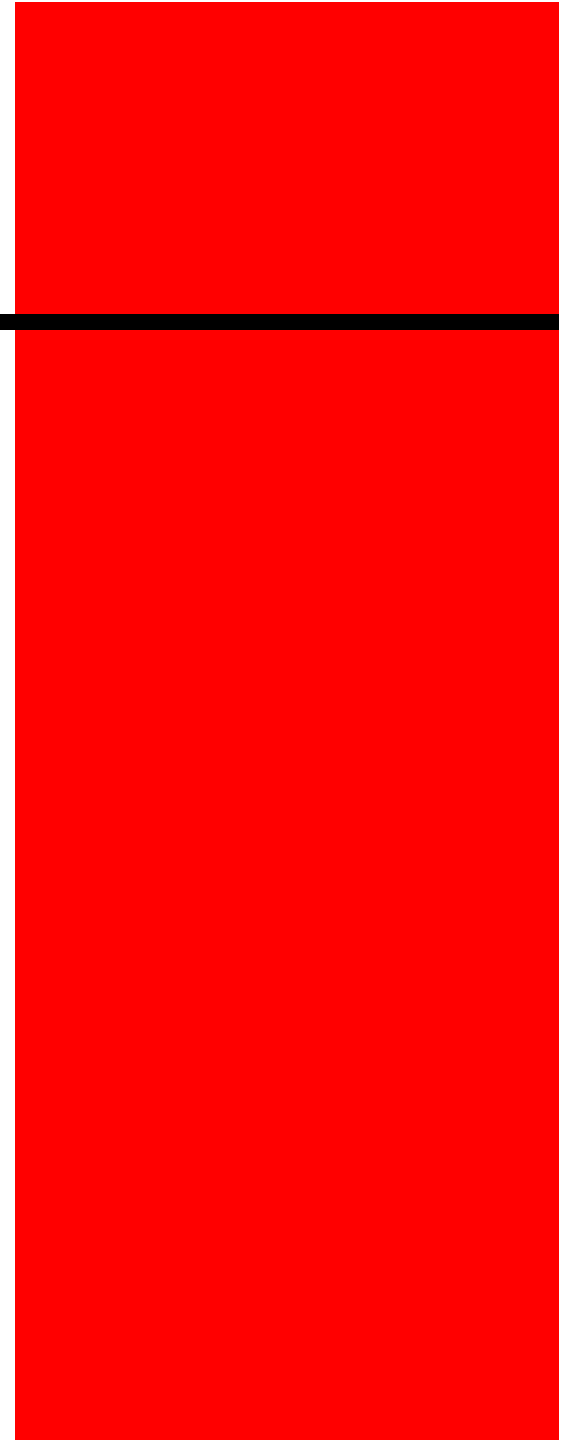

GENERAL START-UP

At the time of Start-Up the installation of the product must be completed in accordance to the instructions in the specific products Installation and Operation Guide. All electrical and gas connections must also be completed in accordance to local codes.

REQUIRED TOOLS

The following tools are required to complete start-ups.

- Standards Hand Tools
- AC/DC Voltage Meter
- Amperage Meter
- Tachometer
- Manometer
- Thermometer
- Gas Pressure Gauge

CHECKLIST PRIOR TO START-UP

- ❑ Check for signs of damage. Do not operate if damage exists and contact your sales person. Damage is easier to fix before the equipment is installed on the roof top.
- ❑ Check all installation clearances

Clearance from Combustibles

Top: 6" Back: 6" Front: 6" Sides: 6" Bottom: 0"

Service Clearances

Allow 24 inches or greater for service accesses

- ❑ Check that unit has been set level and secure
 - The curb must be level to prevent bearing failure
 - Use the supplied gasket between the curb and unit base
 - Screw or weld the unit base to the curb

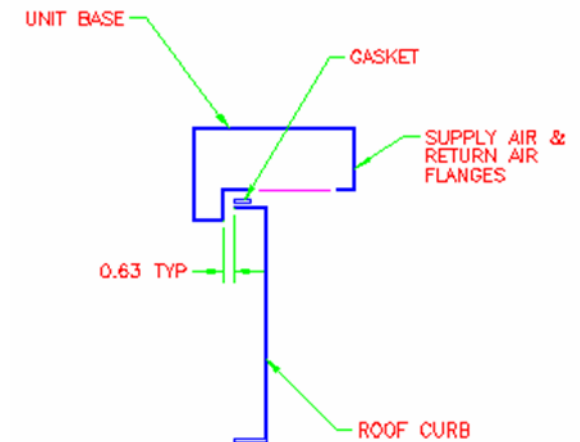

CURB MOUNTING DETAIL

- ❑ Check that the units intake and discharge are free of debris
- ❑ Check that the filters are installed in the (optional) filter section or intake hood in accordance to the filter air flow direction.
- ❑ Check that the units discharge ductwork minimum size matches the manufactures requirement. (See Ductwork Chart)
- ❑ Check that the units discharge ductwork minimum before a turn or transition matches the manufactures requirement to avoid system affects. (See Ductwork Chart)

Ductwork Chart

Blower Size	Duct Size	Duct Length
10	14 x 14	30
12	16 x 16	36
15	20 x 20	45
18	24 x 24	54
20	26 x 26	60
22	30 x 30	66
25	32 x 32	75
27	36 x 36	81
30	38 x 38	90
33	44 x 44	99
36	44 x 44	108
222	30 x 80	30
225	32 x 90	36
227	36 x 100	45
230	38 x 110	54
233	44 x 120	60
236	44 x 130	66

- ❑ Check that all field wiring has been completed in accordance to the factory supplied wiring. Field wires are shown as dashed lines on the wiring prints.
- ❑ Check that terminal screws are tight and wires are in place.
- ❑ Check for pulley alignment

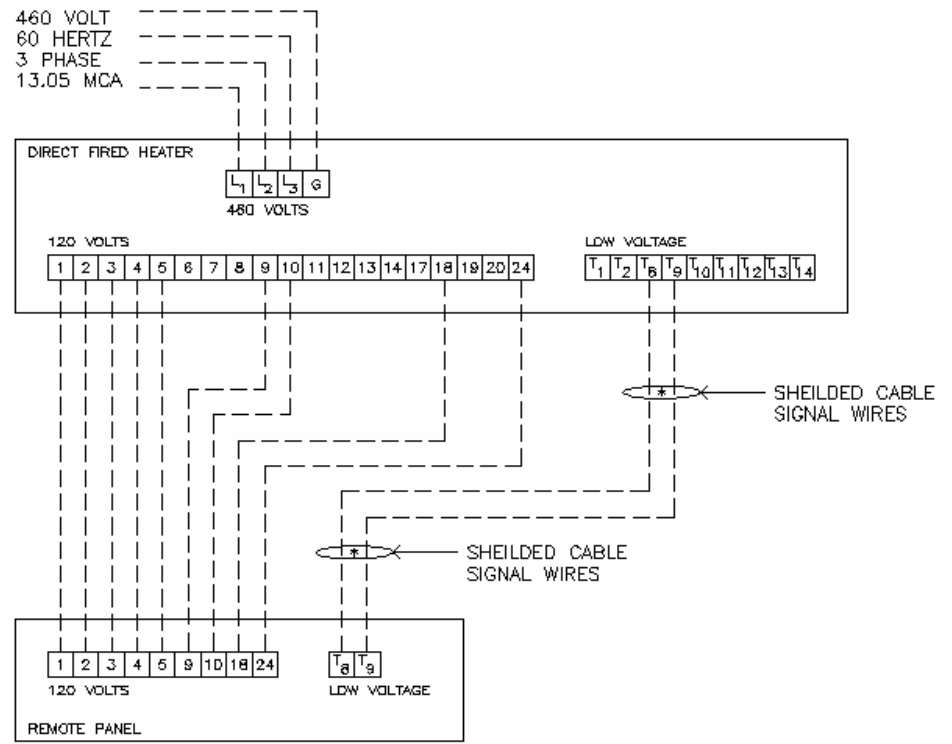
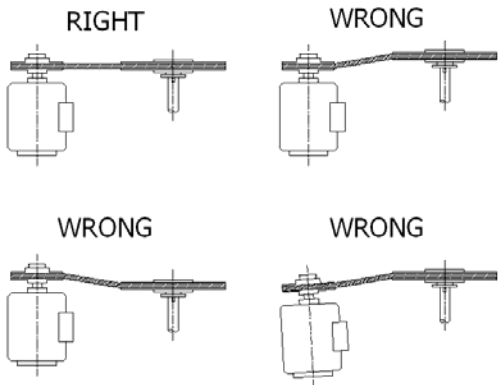

- Check that the power supply matches the nameplate voltage, phase, and amperage.
- Record the voltage on the Start-Up Sheet.
- Check that the gas type and pressure matches the nameplate type and pressure.
- Record the type and pressure on the Start-Up Sheet.
- Contact the service department if the power or gas supply needs to be changed in the field. Different parts might be necessary for the change.



9900958
CONFORMS TO ANSI Std Z83.4

DIRECT INDUSTRIAL AIR HEATER FOR INDUSTRIAL/COMMERCIAL USE
RUPP Air Systems (800)-291-2452
 101 North Industrial Parkway
 West Union, IA 52175

Certified to CSA Std 3.7
 Non-Recirculating
 Direct Industrial Air Hr.

Accepted For Use
 City of New York
 Department of Buildings
 MEA 7-03-E

Gas Type: Natural
 Max. Temp. Rise: 140° F
 Design Temp. Rise: 72° F
 Max. Discharge Temp.: 80° F

MODEL # RAN 27
 Job # 402032 01/16/2006 Fan # 1 - 1 of 1
 Unit Tag: MAU-1

MOTOR				
H.P.	Volts	Phase	Hz	FLA
20.00	208	3	60	55.4

Min. Circuit Ampacity: 72.13 amps
 Hourly B.T.U. Rate (Min./Max.): 73333 / 1496880
 Gas Inlet Pressure (Min./Max.): 1 lb. - 5 lb.
 Max. Manifold Pressure: 5 in. w.c.
 Min. Gas Supply Pressure for Max. Input Adjustment: 1 lb.

MOTOR				
H.P.	Volts	Phase	Hz	FLA
20.00	208	3	60	55.4

<p>Gas Type: Natural</p> <p>Max. Temp. Rise: 140° F</p> <p>Design Temp. Rise: 72° F</p> <p>Max. Discharge Temp.: 80° F</p>	<p>Hourly B.T.U. Rate (Min./Max.): 73333 / 1496880</p> <p>Gas Inlet Pressure (Min./Max.): 1 lb. - 5 lb.</p> <p>Max. Manifold Pressure: 5 in. w.c.</p> <p>Min. Gas Supply Pressure for Max. Input Adjustment: 1 lb.</p>
--	--

COMMERCIAL DIRECT FIRED

- ❑ Turn the Summer-Off-Winter switch to “Winter” on 400 series remote panels
- ❑ Turn the Auto-Off-Manual switch to “Auto” and the Burner-Vent to “Burner” on standard remote panels
- ❑ Set the Maxitrol Set-Point to the maximum.
- ❑ Turn the main power disconnect ON.
- ❑ Bump the blower motor starter to check the blower wheel rotation.
 - If the rotation is backwards turn off the power and correct the wiring.
- ❑ Turn the circuit breaker ON. The (optional) intake or discharge damper motor will start to open. Once the damper is 90% open the damper motor internal end switch will close and energize the blower motor starter.

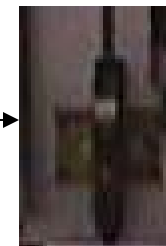
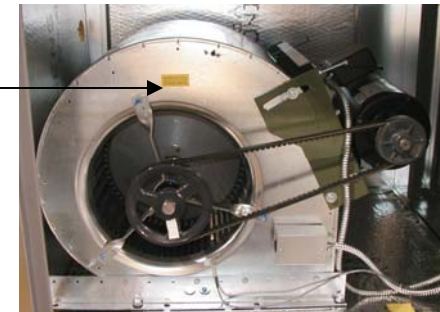
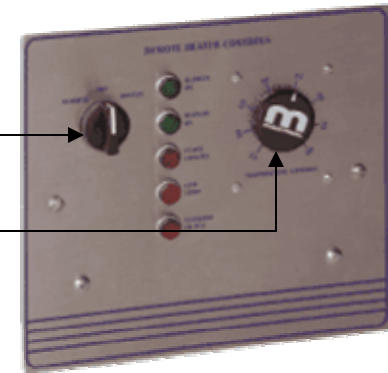

- ❑ Check that the motor amp draw is less than the FLA (full load amps) of the blower motor.
- The fan RPM may need to be reduced to decrease motor amps.
- Opening the driver pulley decreases RPM and motor amps.
- Closing the driver pulley increases RPM and motor amps.
- Record the motor amps on the Start-Up Sheet.
- ❑ If the RPM was adjusted in the field use a tachometer to record the new RPM on the Start-Up Sheet.
- ❑ Check the belt tension after any RPM adjustments. See the belt tension detail.

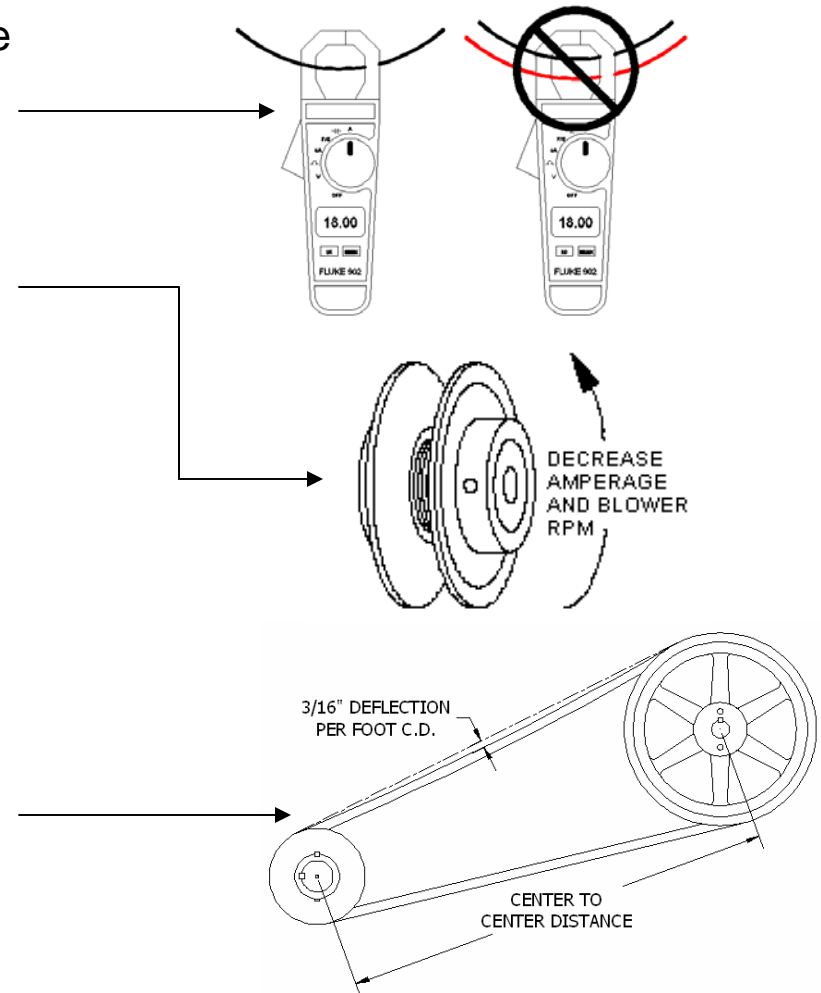

- ❑ Check the air flow pressure drop.
 - This will ensure proper pressure drop across the burner profile.
 - This will also ensure that the air flow switch does not trip on windy days.
 - The air flow switch on the modular unit is a low and high air flow switch only and opens below 0.15 in w.c and 0.65 in w.c.
 - The target pressure drop range for the modular unit is 0.40 – 0.50 in w.c.
- ❑ The spring loaded profile plates should place the pressure drop in a good range, unless the air flow is very high or low. The blower RPM may need to be increased or decreased to reach the target pressure drop.
- ❑ Record the pressure drop on the Start-Up Sheet.

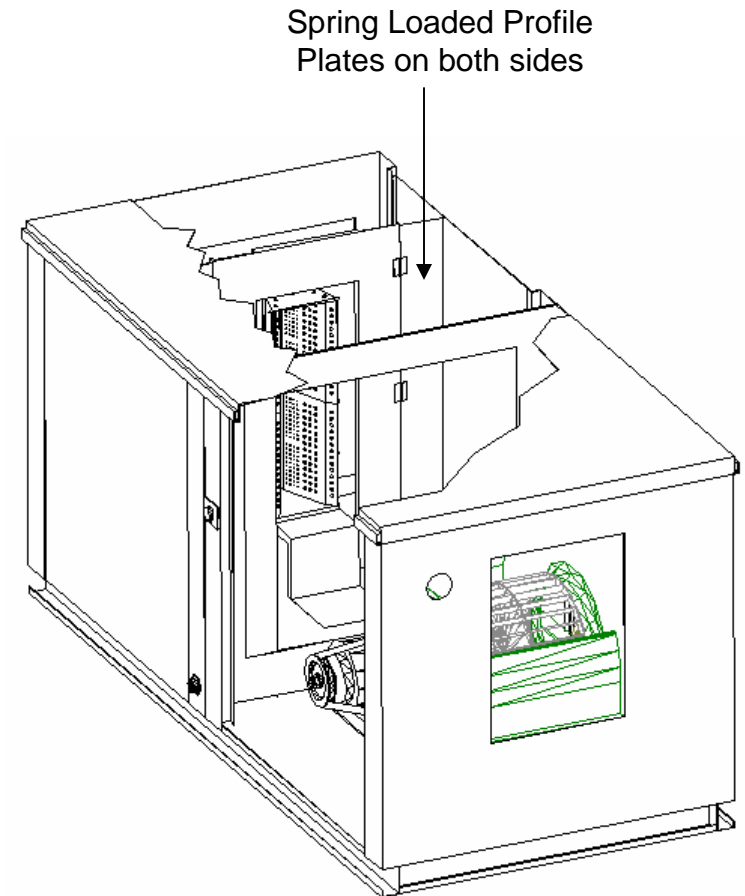

-
- ❑ Close the Burner Gas Shut Off Valve.
 - This will allow the unit to fire the pilot only and will be opened at a later time.

Turn Valve OFF



- ❑ Ensure the Burner Intake On Off Thermostat is set above the outside air temperature.



- ❑ The Fireeye Flame Safety Control energizes the ignition transformer and pilot gas valve.
- ❑ After the pilot flame is established, the main gas valves will open.
- At this time the pilot will be the only flame in the burner.
- ❑ The pilot regulator should be adjusted so the pilot flame signal is above 15 VDC.
- Use the DC terminals under the Fireeye cover to read the pilot flame signal.
- This will ensure that the unit will start in cold damp weather with a strong pilot flame signal.
- ❑ Record the pilot flame signal in the Start-Up Sheet.
- ❑ Record the low and high fire flame signal on the Start-Up Sheet.

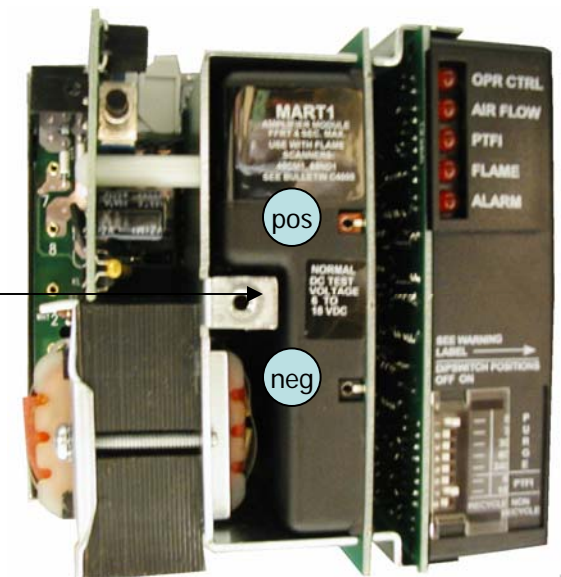
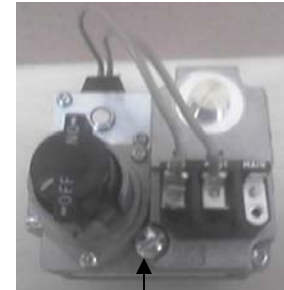

SETTING HIGH FIRE

DISCHARGE TEMPERATURE METHOD

- Open the Burner Gas Shut Off Valve.
- Measure the intake air temperature.
- Add the intake air temperature to the units nameplate design temperature rise.
- This result will be the desired high fire discharge temperature.

Example: Intake Temp 70 F
 Design Temp Rise 72 F
 Discharge Temp 142 F

 DIRECT INDUSTRIAL AIR HEATER FOR INDUSTRIAL/COMMERCIAL USE
RUPP Air Systems (800)-291-2452
101 North Industrial Parkway
West Union, IA 52175
9900938
CONFORMS TO ANSI Std Z83.4
MODEL # RAM 27
Certified to CSA Std 3.7
Non-Recirculating
Direct Industrial Air Htr.
Job # 402032 01/16/2006 Fan # 1 - 1 of 1
Unit Tag: MAU-1
Accepted For Use
City of New York
Department of Buildings
MEA 7-03-E
MOTOR

H.P.	Volts	Phase	Hz	FLA
20.00	208	3	60	55.4

Gas Type: Natural
Max. Temp. Rise: 140° F
Design Temp. Rise: 72° F
Max. Discharge Temp.: 80° F
Min. Circuit Ampacity: 72.13 amps
Hourly B.T.U. Rate (Min./Max.): 73333 / 1496880
Gas Inlet Pressure (Min./Max.): 1 lb. - 5 lb.
Max. Manifold Pressure: 5 in. w.c.
Min. Gas Supply Pressure for Max. Input Adjustment: 1 lb.

Gas Type: Natural
Max. Temp. Rise: 140° F
Design Temp. Rise: 72° F
Max. Discharge Temp.: 80° F

-
- ❑ Use the Maxitrol Amplifier to override the heater into high fire.
 - On the A1014 amplifier remove the #4 wire
 - On the A1044 amplifier remove the #2 and #4 wire
 - On the M-Series adjust the set-point to be 160 F
 - ❑ Adjust the manifold gas pressure to achieve the desired discharge air temperature.
 - See the details for the high fire pressure adjustment locations.
 - Measure the discharge temperature using a thermometer. Laser thermometers are not as accurate as a thermocouple type.
 - If the discharge ductwork outlet is hard to reach, you may feed a thermocouple into the mixing tube inside the blower discharge.

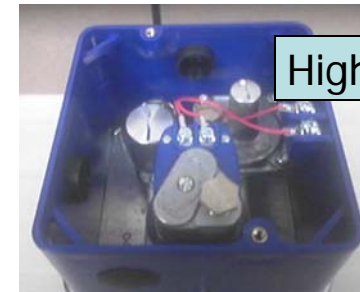

High Fire

MR212D

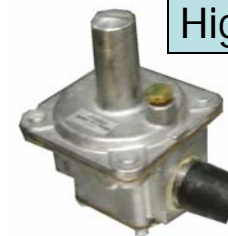

High Fire

M511 &
M611

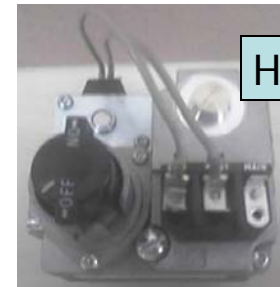

High Fire

36C68

SETTING HIGH FIRE

MANIFOLD PRESSURE METHOD

- Open the Burner Gas Shut Valve.
- Find the Design Manifold Pressure on the units nameplate.

Example: Design Pressure 3.00 inches w.c.

Manifold Pressure **3.00 inches w.c.**

- Set the unit to call for heat.

DIRECT INDUSTRIAL AIR HEATER FOR INDUSTRIAL/COMMERCIAL USE
RUPP Air Systems (800)-291-2452
 101 North Industrial Parkway
 West Union, IA 52175
MODEL # RAM 27
Job # 402032 01/16/2006 Fan # 1 - 1 of 1
Unit Tag: MAU-1

9900938
CONFORMS TO ANSI Std Z83.4

Certified to CSA Std 3.7
 Non-Recirculating
 Direct Industrial Air Htr.

MOTOR				
H.P.	Volts	Phase	Hz	FLA
20.00	208	3	60	55.4

Accepted For Use
 City of New York
 Department of Buildings
 MEA 7-03-E

Gas Type: Natural
 Max. Temp. Rise: 140° F
 Design Temp. Rise: 72° F
 Max. Discharge Temp.: 80° F

Min. Circuit Ampacity: 72.13 amps
 Hourly B.T.U. Rate (Min./Max.): 73333 / 1496880
 Gas Inlet Pressure (Min./Max.): 1 lb. - 5 lb.
 Max. Manifold Pressure: 5 in. w.c.
 Min. Gas Supply Pressure for Max. Input Adjustment: 1 lb.

Design Manifold Pressure: 3.00 in w.c.

- ❑ Use the Maxitrol Amplifier to override the heater into high fire.
 - On the A1014 amplifier remove the #4 wire
 - On the A1044 amplifier remove the #2 and #4 wire
 - On the M-Series adjust the set-point to be 160 F
- ❑ Adjust the manifold gas pressure to achieve the desired manifold pressure.
 - See the details for the high fire pressure adjustment locations.
 - See the detail for the pressure tap location.

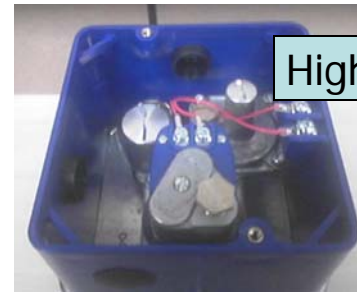

MR212D

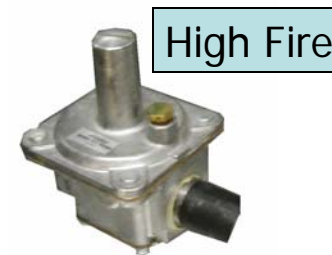

M511 &
M611

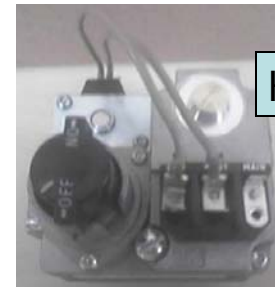

36C68

SETTING LOW FIRE

- ❑ Use the Maxitrol Amplifier to override the heater into low fire.
 - On the A1014 amplifier remove the #8 wire
 - On the A1044 amplifier remove the #8 wire
 - On the M-Series remove the 24V power source
- ❑ Adjust the low fire setting on the modulation valve so the flame is 2 – 3 inches without dark spots.
 - See the details for the low fire pressure adjustment locations.
 - Use the burner observation port on the end of the unit to view the flame size.
- ❑ Replace all the amplifier wires in the place the were removed to set high and low fire.

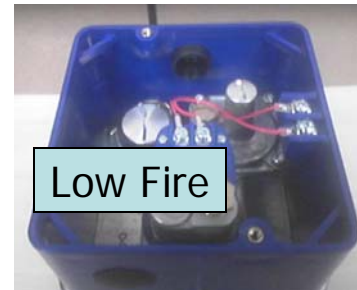

MR212D



M511 &
M611

-
- ❑ Set the Burner Intake On Off Switch to be 50 degrees or 15 degree less than the discharge or room set-point.
 - This will automatically open the burner circuit when the outside air is above the selected temperature.



- ❑ Operate the unit from the remote panel checking the lights, switches, set-point, and optional thermostats or timers.
- ❑ Review the proper operation and sequence of operation with the customer to ensure that the unit is operated properly and that the customer does not misuse the equipment.
- ❑ Complete the Start-Up Sheet and fax to the service department to validate the warranty.
- ❑ **START-UP COMPLETE**