

SMV

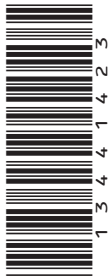

Frequency inverter -----

Operating instructions EN



Lenze

Contents



1	Safety Information	3
2	Technical Data	6
2.1	Standards and Application Conditions	6
2.2	SMV Type Number Designation	7
2.3	Ratings	8
3	Installation	11
3.1	Dimensions and Mounting	11
3.1.1	NEMA 1 (IP31) Models \leq 30HP (22kW)	11
3.2	Electrical Installation	12
3.2.1	Power Connections	12
3.2.1.1	Mains Connection to 120VAC Single-Phase Supply	12
3.2.1.2	Mains Connection to 240VAC Single-Phase Supply	13
3.2.1.3	Mains Connection to Three-Phase Supply	13
3.2.1.4	Motor Connection	13
3.2.1.5	Installation Recommendations for EMC Compliance	14
3.2.2	Fuses/Cable Cross-Sections	15
3.2.3	Control Terminals	16
4	Commissioning	17
4.1	Local Keypad & Display	17
4.2	Drive Display and Modes of Operation	18
4.3	Parameter Setting	19
4.4	Electronic Programming Module (EPM)	19
4.5	Parameter Menu	20
4.5.1	Basic Setup Parameters	20
4.5.2	I/O Setup Parameters	23
4.5.3	Advanced Setup Parameters	25
4.5.4	PID Parameters	28
4.5.5	Vector Parameters	30
4.5.6	Network Parameters	32
4.5.7	Diagnostic Parameters	33
4.5.7.1	Terminal & Protection Status Display	34
4.5.7.2	Keypad Status Display	34
4.5.8	Custom Modbus Instructions for ESVxxxNxxxXB571 models	34
4.5.8.1	Register 2000 - Drive Status Word	36
4.5.8.2	Register 2002 - Drive Fault	36
4.5.8.3	Register 2003 - Drive State	37
4.5.8.4	Register 2012 - Digital Inputs	37
4.5.8.5	Register 2100 - Network Control Word	38
4.5.8.6	Registers 2108 and 2109 - Drive Display Override	39
5.1	Status/Warning Messages	40
5.2	Drive Configuration Messages	41
5.3	Fault Messages	42

About These Instructions

This documentation applies to the SMV frequency inverter and contains important technical data regarding the installation, operation, and commissioning of the inverter.

These instructions are only valid for SMV frequency inverters with Model Number ending in 571.

Please read these instructions in their entirety before commissioning the drive.

A	B	C	D	E	F
 Made in USA Inverter SMVector	Type: ESV751N04TXB Id-No: 00000000	INPUT: 3~ (3/PE) 400/480 V 2.9/2.5 A 50-60 HZ	OUTPUT: 3~ (3/PE) 0 - 400/460 V 2.4/2.1 A 0.75 KW/1HP 0 - 500 HZ	For detailed information refer to instruction Manual: SV01 00000000000000000000 ESV751N04TXB000XX###	
	LISTED  5D81 C US IND. CONT. EQ.	CE TYPE-4X INDOOR USE ONLY 			

A	B	C	D	E	F
Certifications	Type	Input Ratings	Output Ratings	Hardware Version	Software Version

Scope of delivery	Important
<ul style="list-style-type: none"> 1 SMV Inverter with EPM installed (see Section 4.4) 1 Operating Instructions manual 	After receipt of the delivery, check immediately whether the items delivered match the accompanying papers. Lenze AC Tech does not accept any liability for deficiencies claimed subsequently. Claim: <ul style="list-style-type: none"> visible transport damage immediately to the forwarder. visible deficiencies /incompleteness immediately to your Lenze AC Tech representative

Related Documents

The documentation listed herein contains information relevant to the operation of the SMVector frequency inverter. To obtain the latest documentation, visit the Technical Library at <http://www.lenzeamericas.com>.

Document #	Description
CMVINS01	SMVector Communications Module Installation Instruction
CMVMB401	SMVector ModBus RTU over RS485 Communications Reference Guide
CMVLC401	SMVector Lecom Communications Reference Guide
CMVCAN01	SMVector CANopen Communications Reference Guide
CMVDVN01	SMVector DeviceNet Communications Reference Guide
CMVETH01	SMVector EtherNet/IP Communications Reference Guide
CMVFPB01	SMVector PROFIBUS Communications Reference Guide
ALSV01	SMVector Additional I/O Module Installation and Operation Manual
DBV01	SMVector Dynamic Braking
PTV01	SMVector Potentiometer Install Instructions
RKV01	SMVector ESVZXK1 Remote Keypad
RKVU01	SMVector ESVZXH0 Remote Keypad (for NEMA 1 15-60HP (11-45kW) Drives)

Copyright © 2013 - 2006 Lenze AC Tech Corporation

All rights reserved. No part of this manual may be reproduced or transmitted in any form without written permission from Lenze AC Tech Corporation. The information and technical data in this manual are subject to change without notice. Lenze AC Tech Corporation makes no warranty of any kind with respect to this material, including, but not limited to, the implied warranties of its merchantability and fitness for a given purpose. Lenze AC Tech Corporation assumes no responsibility for any errors that may appear in this manual.

All information given in this documentation has been carefully selected and tested for compliance with the hardware and software described. Nevertheless, discrepancies cannot be ruled out. Lenze AC Tech does not accept any responsibility nor liability for damages that may occur. Any necessary corrections will be implemented in subsequent editions. This document is printed in the United States

1 Safety Information

General

Some parts of Lenze AC Tech controllers can be electrically live and some surfaces can be hot. Non-authorized removal of the required cover, inappropriate use, and incorrect installation or operation creates the risk of severe injury to personnel and/or damage to equipment.

All operations concerning transport, installation, and commissioning as well as maintenance must be carried out by qualified, skilled personnel who are familiar with the installation, assembly, commissioning, and operation of variable frequency drives and the application for which it is being used.

Installation

Ensure proper handling and avoid excessive mechanical stress. Do not bend any components and do not change any insulation distances during transport, handling, installation or maintenance. Do not touch any electronic components or contacts. This drive contains electrostatically sensitive components, which can easily be damaged by inappropriate handling. Static control precautions must be adhered to during installation, testing, servicing and repairing of this drive and associated options. Component damage may result if proper procedures are not followed.

To ensure proper operation, do not install the drive where it is subjected to adverse environmental conditions such as combustible, oily, or hazardous vapors; corrosive chemicals; excessive dust, moisture or vibration; direct sunlight or extreme temperatures.

This drive has been tested by Underwriters Laboratory (UL) and is UL Listed in compliance with the UL508C Safety Standard. This drive must be installed and configured in accordance with both national and international standards. Local codes and regulations take precedence over recommendations provided in this and other Lenze AC Tech documentation.

The SMVector drive is considered a component for integration into a machine or process. It is neither a machine nor a device ready for use in accordance with European directives (reference machinery directive and electromagnetic compatibility directive). It is the responsibility of the end user to ensure that the machine meets the applicable standards.

Electrical Connection

When working on live drive controllers, applicable national safety regulations must be observed. The electrical installation must be carried out according to the appropriate regulations (e.g. cable cross-sections, fuses, protective earth [PE] connection). While this document does make recommendations in regards to these items, national and local codes must be adhered to.

The documentation contains information about installation in compliance with EMC (shielding, grounding, filters and cables). These notes must also be observed for CE-marked controllers. The manufacturer of the system or machine is responsible for compliance with the required limit values demanded by EMC legislation.

Application

The drive must not be used as a safety device for machines where there is a risk of personal injury or material damage. Emergency Stops, over-speed protection, acceleration and deceleration limits, etc must be made by other devices to ensure operation under all conditions.

The drive does feature many protection devices that work to protect the drive and the driven equipment by generating a fault and shutting the drive and motor down. Mains power variances can also result in shutdown of the drive. When the fault condition disappears or is cleared, the drive can be configured to automatically restart, it is the responsibility of the user, OEM and/or integrator to ensure that the drive is configured for safe operation.

Safety Information

Explosion Proof Applications

Explosion proof motors that are not rated for inverter use lose their certification when used for variable speed. Due to the many areas of liability that may be encountered when dealing with these applications, the following statement of policy applies:

Lenze AC Tech Corporation inverter products are sold with no warranty of fitness for a particular purpose or warranty of suitability for use with explosion proof motors. Lenze AC Tech Corporation accepts no responsibility for any direct, incidental or consequential loss, cost or damage that may arise through the use of AC inverter products in these applications. The purchaser expressly agrees to assume all risk of any loss, cost or damage that may arise from such application.

Operation

Systems including controllers must be equipped with additional monitoring and protection devices according to the corresponding standards (e.g. technical equipment, regulations for prevention of accidents, etc.). The controller may be adapted to your application as described in this documentation.



DANGER!

- After the controller has been disconnected from the supply voltage, live components and power connection must not be touched immediately, since capacitors could be charged. Please observe the corresponding notes on the controller.
- Close all protective covers and doors prior to and during operation.
- Do not cycle input power to the controller more than once every two minutes.
- For SMVector models that are equipped with a Disconnect Switch (11th character in model number is L or M), the Disconnect Switch is intended as a motor service disconnect and does not provide branch circuit protection to the inverter or motor. When servicing the motor, it is necessary to wait 3 minutes after turning this switch to the off position before working on motor power wiring as the inverter stores electrical power. To service the inverter, it is necessary to remove mains ahead of the drive and wait 3 minutes.

Safety Notifications

All safety information given in these Operating Instructions includes a visual icon, a bold signal word and a description.



Signal Word! (characterizes the severity of the danger)

NOTE (describes the danger and informs on how to proceed)

Icon	Signal Word	Meaning	Consequences if ignored
	DANGER!	Warns of hazardous electrical voltage.	Death or severe injuries.
	WARNING!	Warns of potential, very hazardous situations.	Risk of severe injury to personnel and/or damage to equipment.
	WARNING! Hot Surface	Warns of hot surface and risk of burns. Labels may be on or inside the equipment to alert people that surfaces may reach dangerous temperatures.	Risk of severe injury to personnel.
	STOP!	Warns of potential damage to material and equipment.	Damage to the controller/drive or its environment.
	NOTE	Designates a general, useful note.	None. If observed, then using the controller/drive system is made easier.

Safety Information

Harmonics Notification in accordance with EN 61000-3-2, EN 61000-3-12:

Operation in public supply networks (Limitation of harmonic currents i.a.w. EN 61000-3-2, Electromagnetic Compatibility (EMC) Limits). Limits for harmonic current emissions (equipment input current up to 16A/phase).

Directive	Total Power connected to Mains (public supply)	Additional Measures Required for Compliance (2)
EN 61000-3-2	< 0.5kW	with mains choke
	0.5 ... 1kW	with active filter
	> 1kW	complies without additional measures
EN 61000-3-12	16 ... 75amp	Additional measures are required for compliance with the standard

(1) For compliance with EMC regulations, the permissible cable lengths may change.

(2) The additional measures described only ensure that the controller meets the requirements of the EN 61000-3-2.

The machine/system manufacturer is responsible for the machine's compliance with the regulations.

Safety Information in accordance with EN 61800-5-1:



DANGER! Hazard of Electrical Shock

Capacitors retain charge for approximately 180 seconds after power is removed. Allow at least 3 minutes for discharge of residual charge before touching the drive.



WARNING!

- This product can cause a d.c. current in the PE conductor. Where a residual current-operated (RCD) or monitoring (RCM) device is used for protection in case of direct or indirect contact, only an RCD or RCM Type B is allowed on the supply side of this product.
- Leakage Current may exceed 3.5mA AC. The minimum size of the PE conductor shall comply with local safety regulations for high leakage current equipment.
- In a domestic environment, this product may cause radio interference in which case supplementary mitigation measures may be required.



NOTE

Control and communications terminals provide reinforced insulation (i.e. considered SELV or PELV, providing protection in case of direct contact) when the drive is connected to a power system rated up to 300VAC between phase to ground (PE) and the applied voltage on Terminals 16 and 17 is less than 150VAC between phase to ground. Otherwise, control and communications terminals provide basic insulation.

Safety Information in accordance with UL:

Note for UL approved system with integrated controllers: UL warnings are notes which apply to UL systems. The documentation contains special information about UL.



- Suitable for use on a circuit capable of delivering not more than 200,000 rms symmetrical amperes, at the maximum voltage rating marked on the drive.
- Use minimum 75 °C copper wire only.
- Shall be installed in a pollution degree 2 macro-environment.
- NEMA 1 (IP31) models shall be installed in a pollution degree 2 macro-environment.
- All models are suitable for installation in a compartment handling Conditioned Air (i.e., plenum rated).

Torque Requirements (in accordance with UL) are listed in section 3.2.1, Power Connections.

Technical Data

2 Technical Data

2.1 Standards and Application Conditions

Conformity	CE	Low Voltage (2006/95/EC) & EMC (2004/108/EC) Directives
Approvals	UL508C	Underwriters Laboratories -Power Conversion Equipment
Input voltage phase imbalance	≤ 2%	
Supported Power Systems	TT TN	<ul style="list-style-type: none"> – For central grounded systems, operation is permitted without restrictions. – For corner grounded 400/500V systems, operation is possible but reinforced insulation to control circuits is compromised.
Humidity	≤ 95% non-condensing	
Temperature range	Transport	-25 ... +70°C
	Storage	-20 ... +70°C
	Operation	-10 ... +55°C (with 2.5%/°C current derating above +40°C)
Installation height	0 - 4000m a.m.s.l.	(with 5%/1000 m current derating above 1000m a.m.s.l.)
Vibration resistance	acceleration resistant up to 1.0g	
 Earth leakage current	> 3.5 mA to PE	
Max Permissible Cable Length ⁽¹⁾	≤ 4.0 Hp (3.0 kW)	30 meters shielded, 60 meters un-shielded
	=> 5.0 Hp (3.7 kW)	50 meters shielded, 100 meters un-shielded.
Enclosure	IP31/NEMA 1	IP65/NEMA 4X
	NEMA 1 and NEMA 4X model enclosures are plenum rated in accordance with UL 508C and are suitable for installation in a compartment handling conditioned air.	
Protection measures against	short circuit, earth fault, phase loss, over voltage, under voltage, motor stalling, over temperature, motor overload	
Compliance with EN 61000-3-2 Requirements ⁽²⁾	< 0.5kW	with mains choke
	0.5 ... 1kW	with active filter
	> 1kW	without additional measures
Compliance with EN 61000-3-12 Requirements ⁽²⁾	16 ... 75amp	Additional measures required for compliance with EN 61000-3-12

Operation in public supply networks (Limitation of harmonic currents i.a.w. EN 61000-3-2, Electromagnetic Compatibility (EMC) Limits). Limits for harmonic current emissions (equipment input current up to 16A/phase).

(1) The stated cable lengths are permissible at default carrier frequencies (refer to parameter P166).

(2) The additional measures described only ensure that the controller meets the requirements of the EN 61000-3-2.

The machine/system manufacturer is responsible for the machine's compliance with the regulations.

2.2 SMV Type Number Designation

The table herein lists the SMVector Inverter models used in CaptiveAire systems.

CaptiveAire Model #	Mains Voltage	Hp	kW
ESV751N01SXB571	120 VAC, 1-phase	1.0	0.75
ESV112N01SXB571	120 VAC, 1-phase	1.5	1.1
ESV371N02YXB571	240 VAC, 1- / 3-phase	0.5	0.37
ESV751N02YXB571	240 VAC, 1- / 3-phase	1.0	0.75
ESV112N02TXB571	240 VAC, 3-phase	1.5	1.1
ESV112N02YXB571	240 VAC, 1- / 3-phase	1.5	1.1
ESV152N02YXB571	240 VAC, 1- / 3-phase	2.0	1.5
ESV222N02YXB571	240 VAC, 1- / 3-phase	3.0	2.2
ESV402N02TXB571	240 VAC, 3-phase	5.0	4.0
ESV552N02TXB571	240 VAC, 3-phase	7.5	5.5
ESV752N02TXB571	240 VAC, 3-phase	10	7.5
ESV751N04TXB571	480/400 VAC, 3-phase	1.0	0.75
ESV112N04TXB571	480/400 VAC, 3-phase	1.5	1.1
ESV152N04TXB571	480/400 VAC, 3-phase	2.0	1.5
ESV222N04TXB571	480/400 VAC, 3-phase	3.0	2.2
ESV402N04TXB571	480/400 VAC, 3-phase	5.0	4.0
ESV552N04TXB571	480/400 VAC, 3-phase	7.5	5.5
ESV752N04TXB571	480/400 VAC, 3-phase	10	7.5
ESV751N06TXB571	600 VAC, 3-phase	0.5	0.37
ESV152N06TXB571	600 VAC, 3-phase	2.0	1.5
ESV222N06TXB571	600 VAC, 3-phase	3.0	2.2
ESV402N06TXB571	600 VAC, 3-phase	5.0	4.0
ESV552N06TXB571	600 VAC, 3-phase	7.5	5.5
ESV752N06TXB571	600 VAC, 3-phase	10	7.5



NOTE

Prior to installation make sure the enclosure is suitable for the end-use environment

Variables that influence enclosure suitability include (but are not limited to) temperature, airborne contaminants, chemical concentration, mechanical stress and duration of exposure (sunlight, wind, precipitation).

Technical Data

2.3 Ratings

120V / 240VAC Models

Mains = 120V Single Phase (1/N/PE) (90...132V), 240V Single Phase (2/PE) (170...264V); 48...62Hz							
Type	Power		Mains Current		Output Current		Heat Loss (Watts)
	Hp	kW	120V A	240V A	Cont (In) A	Max I %	N1/IP31
ESV371--1S--	0.5	0.37	9.2	4.6	2.4	200	32
ESV751--1S--	1	0.75	16.6	8.3	4.2	200	52
ESV112--1S--	1.5	1.1	20	10.0	6.0	200	74

NOTES:

Output Current: The Output Current Maximum (%) is a percentage of the Output Current Continuous Amps (In) rating and is adjustable in parameter P171.

240VAC Models

Mains = 240V Single Phase (2/PE) (170...264V); 48...62Hz						
Type	Power		Mains Current	Output Current		Heat Loss (Watts)
	Hp	kW	240V A	Cont (In) A	Max I %	N1/IP31
ESV371--2S--	0.5	0.37	5.1	2.4	200	
ESV751--2S--	1	0.75	8.8	4.2	200	
ESV112--2S--	1.5	1.1	12.0	6.0	200	
ESV152--2S--	2	1.5	13.3	7.0	200	
ESV222--2S--	3	2.2	17.1	9.6	200	

240V Single Phase (2/PE) (170...264V), 240V Three Phase (3/PE) (170...264V); 48...62Hz							
Type	Power		Mains Current		Output Current		Heat Loss (Watts)
	Hp	kW	1~ (2/PE) A	3~ (3/PE) A	Cont (In) A	Max I %	N1/IP31
ESV371--2Y--	0.5	0.37	5.1	2.9	2.4	200	27
ESV751--2Y--	1	0.75	8.8	5.0	4.2	200	41
ESV112--2Y--	1.5	1.1	12.0	6.9	6.0	200	64
ESV152--2Y--	2	1.5	13.3	8.1	7.0	200	75
ESV222--2Y--	3	2.2	17.1	10.8	9.6	200	103

Technical Data

240V Three Phase (3/PE) (170...264V); 48...62Hz						
Type	Power		Mains Current	Output Current		Heat Loss (Watts)
	Hp	kW	240V A	Cont (I _n) A	Max I %	N1/IP31
ESV112--2T--	1.5	1.1	6.9	6	200	64
ESV152--2T--	2	1.5	8.1	7	200	75
ESV222--2T--	3	2.2	10.8	9.6	200	103
ESV402--2T--	5	4.0	18.6	16.5	200	154
ESV552--2T--	7.5	5.5	26	23	200	225
ESV752--2T--	10	7.5	33	29	200	274

NOTES:

Output Current: The Output Current Maximum (%) is a percentage of the Output Current Continuous Amps (I_n) rating and is adjustable in parameter P171.

400...480VAC Models

400 ... 480V Three Phase (3/PE) (400V: 340...440V), (480V: 340...528V); 48...62Hz									
Type	Power		Mains Current		Output Current				Heat Loss (Watts)
	Hp	kW	400V A	480V A	Cont (I _n) A		Max I %		
					400V	480V	400V	480V	
ESV371--4T--	0.5	0.37	1.7	1.5	1.3	1.1	175	200	23
ESV751--4T--	1	0.75	2.9	2.5	2.4	2.1	175	200	37
ESV112--4T--	1.5	1.1	4.2	3.6	3.5	3.0	175	200	48
ESV152--4T--	2	1.5	4.7	4.1	4.0	3.5	175	200	57
ESV222--4T--	3	2.2	6.1	5.4	5.5	4.8	175	200	87
ESV302--4T--	4	3.0	8.3	7.0	7.6	6.3	175	200	
ESV402--4T--	5	4.0	10.6	9.3	9.4	8.2	175	200	128
ESV552--4T--	7.5	5.5	14.2	12.4	12.6	11.0	175	200	178
ESV752--4T--	10	7.5	18.1	15.8	16.1	14.0	175	200	208

NOTES:

Output Current: The Output Current Maximum (%) is a percentage of the Output Current Continuous Amps (I_n) rating and is adjustable in parameter P171.

For 400...480 VAC models, the output current maximum (%) in the 400V column is used when P107 = 0

For 400...480 VAC models, the output current maximum (%) in the 480V column is used when P107 = 1

Technical Data

600VAC Models

600V Three Phase (3/PE) (425...660V); 48...62Hz						
Type	Power		Mains Current	Output Current		Heat Loss (Watts)
	Hp	kW	A	Cont (I_n) A	Max I %	N1/IP31
ESV751--6T--	1	0.75	2	1.7	200	37
ESV152--6T--	2	1.5	3.2	2.7	200	51
ESV222--6T--	3	2.2	4.4	3.9	200	68
ESV402--6T--	5	4	6.8	6.1	200	101
ESV552--6T--	7.5	5.5	10.2	9	200	148
ESV752--6T--	10	7.5	12.4	11	200	172

NOTES:

Output Current: The Output Current Maximum (%) is a percentage of the Output Current Continuous Amps (I_n) rating and is adjustable in parameter P171.



STOP!

- For installations above 1000m a.m.s.l., derate I_n by 5% per 1000m, do not exceed 4000m a.m.s.l.
- Operation above 40°C, derate I_n by 2.5% per °C, do not exceed 55°C.

Output Current (I_n) derating for Carrier Frequency (P166) for NEMA 1 (IP31) Models:

- If P166=2 (8 kHz), derate I_n to 92% of drive rating
- If P166=3 (10 kHz), derate I_n to 84% of drive rating

Output Current (I_n) derating for Carrier Frequency (P166) for NEMA 4X (IP65) Models:

- If P166=1 (6 kHz), derate I_n to 92% of drive rating
- If P166=2 (8 kHz), derate I_n to 84% of drive rating
- If P166=3 (10 kHz), derate I_n to 76% of drive rating

3 Installation

3.1 Dimensions and Mounting



WARNING!

Drives must not be installed where subjected to adverse environmental conditions such as: combustible, oily, or hazardous vapors; corrosive chemicals; excessive dust, moisture or vibration; direct sunlight or extreme temperatures.

3.1.1 NEMA 1 (IP31) Models < 30HP (22kW)

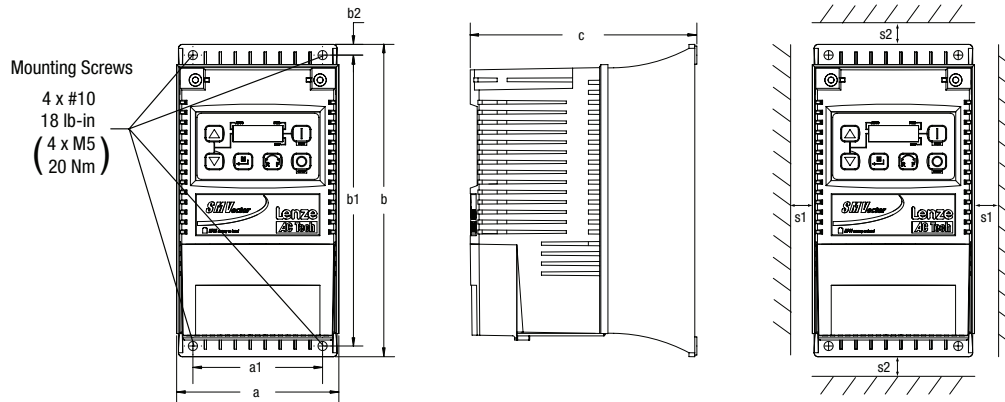

Type	a in (mm)	a1 in (mm)	b in (mm)	b1 in (mm)	b2 in (mm)	c in (mm)	s1 in (mm)	s2 in (mm)	m lb (kg)
G1 ESV251~~~~~B; ESV371~~~~~B ESV751~~~~~B	3.90 (99)	3.12 (79)	7.48 (190)	7.00 (178)	0.24 (6)	4.35 (111)	0.6 (15)	2.0 (50)	2.0 (0.9)
G2 ESV112~~~~~B; ESV152~~~~~B ESV222~~~~~B	3.90 (99)	3.12 (79)	7.52 (191)	7.00 (178)	0.26 (7)	5.45 (138)	0.6 (15)	2.0 (50)	2.8 (1.3)
G3 ESV402~~~~~B	3.90 (99)	3.12 (79)	7.52 (191)	7.00 (178)	0.30 (8)	5.80 (147)	0.6 (15)	2.0 (50)	3.2 (1.5)
H1 ESV552~~~~~B; ESV752~~~~~B	5.12 (130)	4.25 (108)	9.83 (250)	9.30 (236)	0.26 (7)	6.30 (160)	0.6 (15)	2.0 (50)	6.0 (2.0)
J1 ESV113~~~~~B; ESV153~~~~~B ESV183~~~~~B; ESV223~~~~~B	6.92 (176)	5.75 (146)	12.50 (318)	11.88 (302)	0.31 (8)	8.09 (205)	0.6 (15)	2.0 (50)	13.55 (6.15)

Conduit Hole Dimensions	Type	N in (mm)	P in (mm)	P1 in (mm)	Q in (mm)	S in (mm)
	G1	1.84 (47)	1.93 (49)	.70 (18)	1.00 (25)	.88 (22)
	G2	1.84 (47)	3.03 (77)	.70 (18)	1.00 (25)	.88 (22)
	G3	1.84 (47)	3.38 (86)	.70 (18)	1.00 (25)	.88 (22)
	H1	2.46 (62)	3.55 (90)	.13 (3)	1.38 (35)	1.13 (29) .88 (22)
	J1	3.32 (84)	4.62 (117)	.73 (19)	1.40 (36)	1.31 (33) .88 (22)

Installation

3.2 Electrical Installation

Installation After a Long Period of Storage



STOP!

Severe damage to the drive can result if it is operated after a long period of storage or inactivity without reforming the DC bus capacitors.

If input power has not been applied to the drive for a period of time exceeding three years (due to storage, etc), the electrolytic DC bus capacitors within the drive can change internally, resulting in excessive leakage current. This can result in premature failure of the capacitors if the drive is operated after such a long period of inactivity or storage.

In order to reform the capacitors and prepare the drive for operation after a long period of inactivity, apply input power to the drive for 8 hours prior to actually operating the motor.

3.2.1 Power Connections



STOP!

If the kVA rating of the AC supply transformer is greater than 10 times the input kVA rating of the drive(s), an isolation transformer or 2-3% input line reactor must be added to the line side of the drive(s).



DANGER! Hazard of electrical shock!

Circuit potentials up to 600 VAC are possible. Capacitors retain charge after power is removed. Disconnect power and wait at least three minutes before servicing the drive.



STOP!

- Verify mains voltage before connecting to drive.
- Do not connect mains power to the output terminals (U,V,W)! Severe damage to the drive will result.
- Do not cycle mains power more than once every two minutes. Damage to the drive may result.

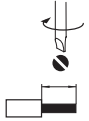
	Mains and Motor Terminations		
	Type	Torque	Strip Length
	<5HP	12 lb-in (1.3 Nm)	5/16 in (8mm)
	ESV552xx2T, ESV752xx2T, ESV113xx4/6, ESV153xx4/6, ESV183xx6, ESV223xx6	16 lb-in (1.8 Nm)	5/16 in (8mm)
	ESV552xx4Txx, ESV752xx4Txx, ESV552xx6Txx, ESV752xx6Txx	12 lb-in (1.3Nm)	0.25 in (6mm)
	ESV113xx2xxx, ESV153xx2xxx, ESV183xx4xxx, ESV223xx4xxx, ESV303xx4xxx	24 lb-in (2.7 Nm)	7/16 in (10mm)
	ESV373xx4xxx, ESV453xx4xxx	27 lb-in (3.05 Nm)	0.75 in (19mm)

3.2.1.1 Mains Connection to 120VAC Single-Phase Supply

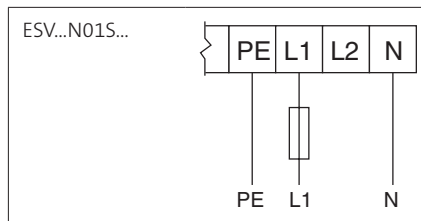

3.2.1.2 Mains Connection to 240VAC Single-Phase Supply

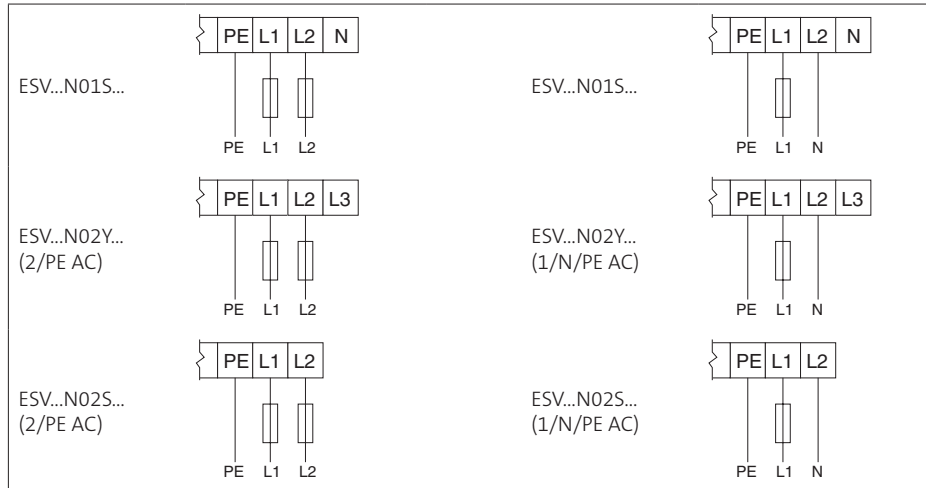

3.2.1.3 Mains Connection to Three-Phase Supply

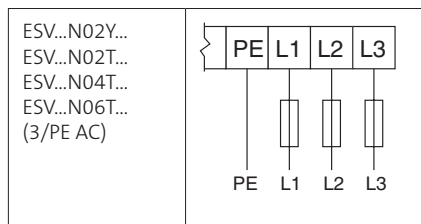

3.2.1.4 Motor Connection

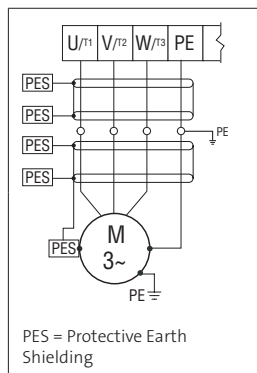

WARNING!

If the cable connection between the drive and the motor has an in-line contactor or circuit breaker then the drive must be stopped prior to opening/closing the contacts. Failure to do so may result in overcurrent trips and/or damage to the inverter.



WARNING!

Leakage current may exceed 3.5 mA AC. The minimum size of the protective earth (PE) conductor shall comply with local safety regulations for high leakage current equipment.



STOP!

In the case of a Spinning Motor:

To bring free-wheeling loads such as fans to a rest before starting the drive, use the DC injection braking function. Starting a drive into a freewheeling motor creates a direct short-circuit and may result in damage to the drive.

Confirm motor suitability for use with DC injection braking.

Consult parameter P110 for starting / restarting into spinning motors.

Installation

3.2.1.5 Installation Recommendations for EMC Compliance

For compliance with EN 61800-3 or other EMC standards, motor cables, line cables and control or communications cables must be shielded with each shield/screen clamped to the drive chassis. This clamp is typically located at the conduit mounting plate.

The EMC requirements apply to the final installation in its entirety, not to the individual components used. Because every installation is different, the recommended installation should follow these guidelines as a minimum. Additional equipment (such as ferrite core absorbers on power conductors) or alternative practices may be required to meet conformance in some installations.

Motor cable should be low capacitance (core/core <75pF/m, core/shield <150pF/m). Filtered drives can meet the class A limits of EN 55011 and EN 61800-3 Category 2 with this type of motor cable up to 10 meters.

NOTE: Refer to Appendix A for recommended cable lengths. Any external line filter should have its chassis connected to the drive chassis by mounting hardware or with the shortest possible wire or braid.

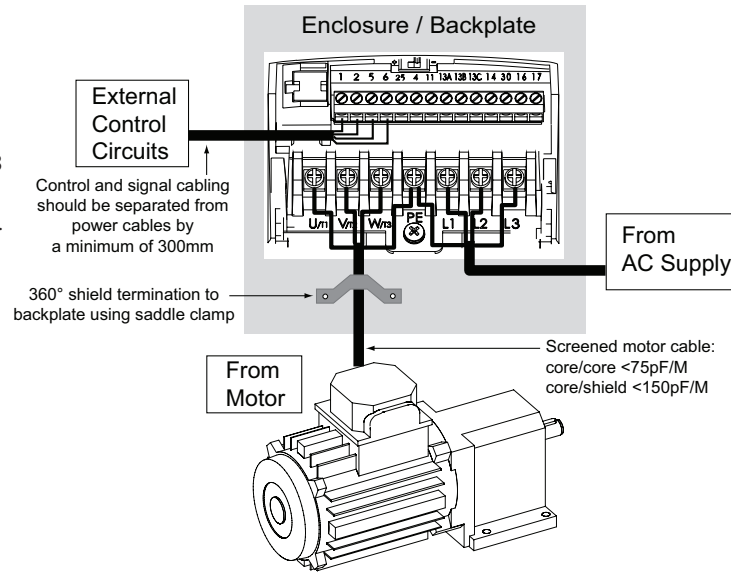

3.2.2 Fuses/Cable Cross-Sections

i **NOTE:** Observe local regulations. Local codes may supersede these recommendations

⚠ **WARNING:** Per UL, use a FUSE for 240V drives requiring >40A protection and for 400/480/600V drives requiring >32A protection.

Type		Recommendations					
		Fuse	Miniature circuit breaker ⁽¹⁾	Fuse ⁽²⁾	Breaker ⁽³⁾	Input Power Wiring (L1, L2, L3, PE)	
				North America		[mm ²]	[AWG]
120V 1~ (1/N/PE)	ESV251N01SXB	M10 A	C10 A	10 A	10 A	1.5	14
	ESV371N01SXB	M16 A	C16 A	15 A	15 A	2.5	14
	ESV751N01SXB	M25 A	C25 A	25 A	25 A	4	10
	ESV112N01SXB	M32 A	C32 A	30A	30A	4	10
240V 1~ (2/PE)	ESV251N01SXB, ESV251N02SXB, ESV371N01SXB, ESV371N02YXB	M10 A	C10 A	10 A	10 A	1.5	14
	ESV751N01SXB, ESV751N02YXB	M16 A	C16 A	15 A	15 A	2.5	14
	ESV112N02YXB, ESV112N01SXB	M20 A	C20 A	20 A	20 A	2.5	12
	ESV152N02YXB	M25 A	C25 A	25 A	25 A	2.5	12
	ESV222N02YXB	M32 A	C32A	30 A	30 A	4	10
240V 3~ (3/PE)	ESV371N02YXB, ESV751N02YXB	M10 A	C10 A	10 A	10 A	1.5	14
	ESV112N02YXB, ESV152N02YXB, ESV112N02TXB, ESV152N02TXB	M16 A	C16 A	12 A	12 A	1.5	14
	ESV222N02YXB, ESV222N02TXB	M20 A	C20 A	20 A	20 A	2.5	12
	ESV402N02TXB	M32 A	C32 A	30 A	30 A	4.0	10
	ESV552N02TXB	M40 A	C40 A	35 A	35 A	6.0	8
	ESV752N02TXB	M50 A	C50 A	45 A		10	8
	ESV113N02TXB	M80 A	C80 A	80 A		16	6
	ESV153N02TXB	M100 A	C100 A	90 A		16	4
400V or 480V 3~(3/PE)	ESV371N04TXB ...ESV222N04TXB	M10 A	C10 A	10 A	10 A	1.5	14
	ESV402N04TXB	M16 A	C16 A	20 A	20 A	2.5	14
	ESV552N04TXB	M20 A	C20 A	20 A	20 A	2.5	14
	ESV752N04TXB	M25 A	C25 A	25 A	25 A	4.0	10
	ESV113N04TXB	M40 A	C40 A	40 A		4	8
	ESV153N04TXB	M50 A	C50 A	50 A		10	8
	ESV183N04TXB	M63 A	C63A	70 A		10	6
	ESV223N04TXB	M80 A	C80 A	80 A		16	6
600V 3~(3/PE)	ESV751N06TXB ...ESV222N06TXB	M10 A	C10 A	10 A	10 A	1.5	14
	ESV402N06TXB	M16 A	C16 A	12 A	12 A	1.5	14
	ESV552N06TXB	M16 A	C16 A	15 A	15 A	2.5	14
	ESV752N06TXB	M20 A	C20 A	20 A	20 A	2.5	12
	ESV113N06TXB	M32 A	C32 A	30 A	30 A	4	10
	ESV153N06TXB	M40 A	C40 A	40 A		4	8
	ESV183N06TXB	M50 A	C50 A	50 A		6	8
	ESV223N06TXB	M63 A	C63 A	60 A		10	8

Notes for Fuse and Cable Table:

- (1) Installations with high fault current due to large supply mains may require a type D circuit breaker.
- (2) UL Class CC or T fast-acting current-limiting type fuses, 200,000 AIC, preferred. Bussman KTK-R, JIN or JJS or equivalent.
- (3) Thermomagnetic type breakers preferred.

Observe the following when using Ground Fault Circuit Interrupters (GFCIs):

- Installation of GFCI only between supplying mains and controller.
- The GFCI can be activated by:
 - capacitive leakage currents between the cable screens during operation (especially with long, screened motor cables)
 - connecting several controllers to the mains at the same time
 - RFI filters

Installation

3.2.3 Control Terminals

Serial Communication Ports:

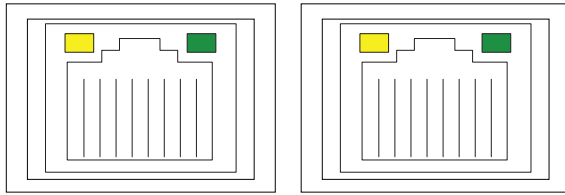

**Dual port RJ-45
For Modbus RS-485
Daisy Chaining**

Control Terminals:

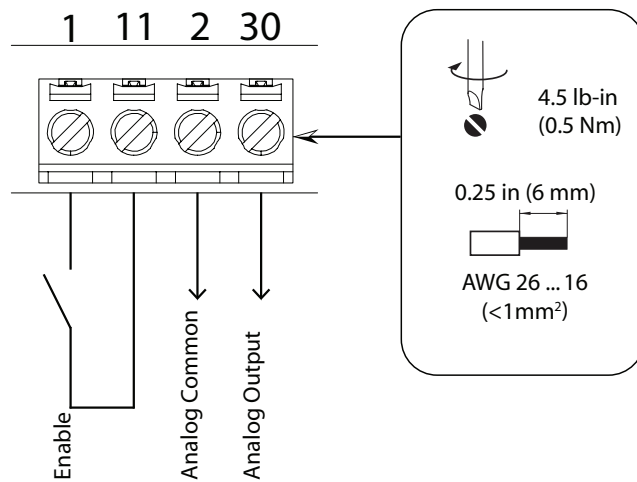

Control Terminal Strip Descriptions

Terminal	Description	Important
1	Digital Input: Start/Stop	input resistance = 2.6k Ω
11	Internal DC supply for external devices	+12 VDC, max. 50 mA
2	Analog Common	
30	Analog Output: Configurable with P150...P155	0...10 VDC, max. 20 mA





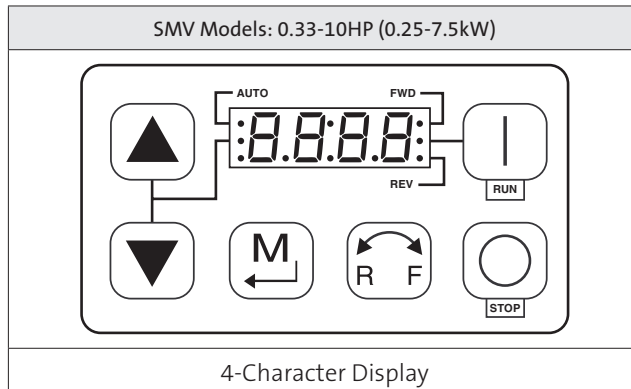

4 Commissioning

4.1 Local Keypad & Display



Display	START BUTTON
	In Local Mode (P100 = 0, 4, 6), this button will start the drive.
	STOP BUTTON
	Stops the drive, regardless of which mode the drive is in. ⚠ WARNING! When JOG is active, the STOP button will not stop the drive!
	ROTATION
	In Local Mode (P100 = 0, 4, 6), this selects the motor rotation direction: <ul style="list-style-type: none"> - The LED for the present rotation direction (FWD or REV) will be on - Press R/F; the LED for the opposite rotation direction will blink - Press M within 4 seconds to confirm the change - The blinking direction LED will turn on, and the other LED will turn off When rotation direction is changed while the drive is running, the commanded direction LED will blink until the drive is controlling the motor in the selected direction. Rotation is set in P112. When P112 = 0, rotation is forward only. When P112 = 1 rotation is forward and reverse.
	MODE
	Used to enter/exit the Parameter Menu when programming the drive and to enter a changed parameter value.
	UP AND DOWN BUTTONS
	Used for programming and can also be used as a reference for speed, PID setpoint, or torque setpoint.
	When the ▲ and ▼ buttons are the active reference, the middle LED on the left side of the display will be on.

Commissioning

Display	INDICATING LEDs (on 4-character display)
	FWD LED: Indicate the present rotation direction is forward. Refer to ROTATION description above.
	REV LED: Indicate the present rotation direction is reverse. Refer to ROTATION description above.
	AUTO LED: Indicates that the drive has been put into Auto mode from one of the TB13 inputs (P121...P124 set to 1...7). Indicates that PID mode is active (if PID mode is enabled). Indicates that sequencer mode is active (if sequencer mode is enabled).
	RUN LED: Indicates that the drive is running.
	▲ ▼ LED: Indicates that the ▲ ▼ are the active reference.
	NOTE If the keypad is selected as the auto reference (P121...P124 is 6) and the corresponding TB-13 input is closed, the AUTO LED and ▲ ▼ LEDs will both be on.

4.2 Drive Display and Modes of Operation

Speed Mode Display

In the standard mode of operation, the drive frequency output is set directly by the selected reference (keypad, analog reference, etc.). In this mode, the drive display will show the drive's output frequency.

PID Mode Display

When the PID mode is enabled and active, the normal run display shows the actual PID setpoint. When PID mode is not active, the display returns to showing the drive's output frequency.

Torque Mode Display

When the drive is operating in Vector Torque mode, the normal run display shows the drive's output frequency.

Alternate (Run-Screen) Display

When P179 (Run Screen Display) is set to a value other than 0, one of the diagnostic parameters (P501...P599) is displayed. Example: if P179 is set to 1, then diagnostic parameter P501 (Software version) is displayed. If P179 =2, then P502 (Drive ID) is displayed.

4.3 Parameter Setting

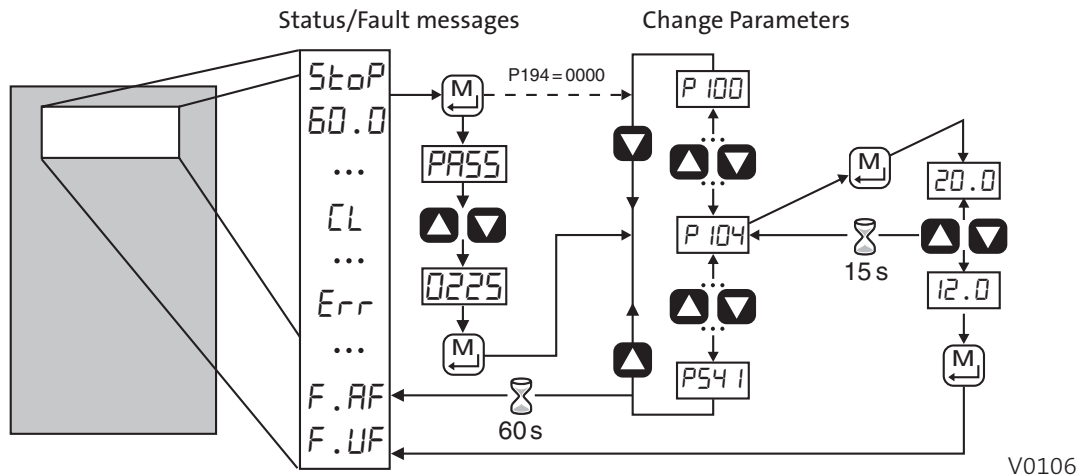

4.4 Electronic Programming Module (EPM)

The EPM contains the drives operational memory. Parameter settings are stored in the EPM and setting changes are made to the “User settings” in the EPM.

An optional EPM Programmer (model EEPM1RA) is available that allows:

- An EPM to be copied directly to another EPM.
- An EPM to be copied to the memory of the EPM Programmer.
- Stored files can be modified in the EPM Programmer.
- Stored files can be copied to another EPM.

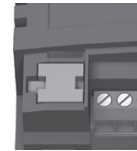

EPM Module in SMV Drive

As the EPM Programmer is battery operated, parameter settings can be copied to an EPM and inserted into a drive without power being applied to the drive. This means that the drive will be fully operational with the new settings on the next application of power.

Additionally, when the drives parameter settings are burned into an EPM with the EPM Programmer, the settings are saved in two distinct locations; the “User settings” and the “OEM default settings”. While the User settings can be modified in the drive, the OEM settings cannot. Thus, the drive can be reset not only to the “factory” drive default settings (shown in this manual), but can be set to the Original Machine settings as programmed by the OEM.





The user area contents of the EPM are what are copied into the OEM space by the EPM programmer. When parameter modifications are made to the drive and then a copy made via the EPM Programmer, these are the settings that will be available by the OEM selections from P199. The EPM Programmer is the only way to load the OEM area of the EPM.

While the EPM can be removed for copying or to use in another drive, it must be installed for the drive to operate (a missing EPM will trigger an **F.F I** fault)

Commissioning

4.5 Parameter Menu



4.5.1 Basic Setup Parameters

Code		Possible Settings			IMPORTANT	
No.	Name	Default	Selection			
P 100	Start Control Source	0	0	Local Keypad	Use RUN button on front of drive to start	
			1	Terminal Strip	Use start/stop circuit wired into the terminal strip. Refer to section 3.2.3	
			2	Network Only	<ul style="list-style-type: none"> Start command must come from network (Modbus, CANopen, etc) SMV models <15HP (11kW) require optional communication module (refer to the network module documentation). 	
			WARNING! P100 = 0 disables TB-1 as a STOP input! STOP circuitry may be disabled if parameters are reset back to defaults (see P199)			
			NOTE <ul style="list-style-type: none"> The STOP button on the front of the drive is always active except in JOG mode. TB-1 is an active STOP input if P100 is set to a value other than 0. 			
P 101	Standard Reference Source	0	0	Keypad (Local or Remote)	Selects the default speed or torque reference when no Auto Reference is selected using the TB-13 input.	
			1	0-10 VDC		
			2	4-20 mA		
			3	Preset #1 (P131)		
			4	Preset #2 (P132)		
			5	Preset #3 (P133)		
			6	Network	Selections 7, 8 & 9 are not valid for PID setpoint or torque reference.	
			7	Preset Sequence Segment #1 (P710)		
			8	Preset Sequence Segment #2 (P715)		
			9	Preset Sequence Segment #3 (P720)		
P 102	Minimum Frequency	0.0	0.0	{Hz}	P103	<ul style="list-style-type: none"> P102, P103 are active for all speed references When using an analog speed reference, also see P160, P161
P 103	Maximum Frequency	80.0	7.5	{Hz}	500	 NOTE <ul style="list-style-type: none"> P103 cannot be set below Minimum Frequency (P102) To set P103 above 120 Hz: <ul style="list-style-type: none"> Scroll up to 120 Hz; display shows HiFr (flashing). Release ▲ button and wait one second. Press ▲ button again to continue increasing P103.
	WARNING! Consult motor/machine manufacturer before operating above rated frequency. Overspeeding the motor/machine may cause damage to equipment and injury to personnel!					
P 104	Acceleration Time 1	30.0	0.0	{s}	3600	<ul style="list-style-type: none"> P104 = time of frequency change from 0 Hz to P167 (base frequency) P105 = time of frequency change from P167 to 0 Hz For S-ramp accel/decel, adjust P106
P 105	Deceleration Time 1	30.0	0.0	{s}	3600	
	EXAMPLE: IF P103 = 120 Hz, P104 = 20.0 s and P167 (base frequency) = 60 Hz; then the rate of frequency change from 0 Hz to 120 Hz = 40.0 s					
P 106	S-Ramp Integration Time	0.0	0.0	{s}	50.0	<ul style="list-style-type: none"> P106 = 0.0: Linear accel/decel ramp P106 > 0.0: Adjusts S-ramp curve for smoother ramp

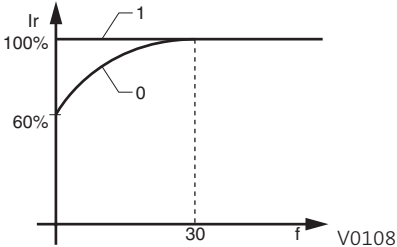

Commissioning

Code		Possible Settings		IMPORTANT
No.	Name	Default	Selection	
P 107 ¹³	Line Voltage Selection	1*	0 Low (120, 200, 400, 480VAC) 1 High (120, 240, 480, 600VAC)	* The default setting is 1 for all drives except when using "Reset to 50Hz default settings" (Parameter P199, selection 4) with 480V models. In this case, the default setting is 0.
P 108	Motor Overload	100	30 {%} 100	P108 = motor current rating x 100 SMV output rating Example: if motor = 3amps and SMV = 4amps, then P108 = 75%
			NOTE Do not set above rated motor current as listed on the motor dataplate. The motor thermal overload function of the SMV is UL approved as a motor protection device. Cycling power after an overload fault could result in significantly reducing the motor life.	
P 109	Motor Overload Type	0	0 Speed Compensation Reduces the allowable continuous current when operating below 30Hz. 1 No Speed Compensation Example: Motor is cooled by forced ventilation as apposed to shaft mounted, self cooling fans.	 <p>Ir: rated current (%), f: motor frequency (Hz)</p>

Commissioning

Code		Possible Settings		IMPORTANT
No.	Name	Default	Selection	
P110	Start Method	3	0 Normal	<p>Drive will automatically start when power is applied.</p> <p>When start command is applied, drive will apply DC braking according to P174, P175 prior to starting the motor</p> <p>Drive will automatically restart after faults, or when power is applied.</p> <p>Combines settings 2 and 3</p> <ul style="list-style-type: none"> Drive will automatically restart after faults, or when power is applied. After 3 failed attempts, drive will Auto Restart with DC brake. P110 = 5, 7: Performs speed search, starting at Max Frequency (P103) P110 = 6, 8: Performs speed search, starting at the last output frequency prior to faulting or power loss If P111 = 0, a flying START is performed when a start command is applied. P110 = 7, 8: Utilizes P280/281 to set Max Current Level and Decel Time for restart
			1 Start on Power-up	
			2 Start with DC Brake	
			3 Auto Restart	
			4 Auto Restart with DC Brake	
			5 Flying Start/Restart - Type 1	
			6 Flying Start/Restart - Type 1	
			7 Flying Start /Restart - Type 2 for 2-pole motors requiring a flying restart	
8 Flying Start/Restart - Type 2 for 2-pole motors requiring a flying restart				
		 <p>NOTE</p> <ul style="list-style-type: none"> P110 = 0, 2: Start command must be applied at least 2 seconds after power-up; FUF fault will occur if start command is applied too soon. P110 = 1, 3...6: For automatic start/restart, the start source must be the terminal strip and the start command must be present. P110 = 2, 4...6: If P175=999.9, dc braking will be applied for 15s. P110 = 3...6: Drive will attempt 5 restarts; if all restart attempts fail, drive displays LC (fault lockout) and requires manual reset. P110 = 5, 6: If drive cannot catch the spinning motor, drive will trip into F.rF fault. P110 = 5, 6: If drive trips into F.DF fault, try P110 = 7 or 8. 		
 <p>WARNING! Automatic starting/restarting may cause damage to equipment and/or injury to personnel! Automatic starting/restarting should only be used on equipment that is inaccessible to personnel.</p>				
P111	Stop Method	0	0 Coast	<p>Drive's output will shut off immediately upon a stop command, allowing the motor to coast to a stop</p> <p>The drive's output will shut off and then the DC Brake will activate (refer to P174, P175)</p> <p>The drive will ramp the motor to a stop according to P105 or P126.</p> <p>The drive will ramp the motor to 0 Hz and then the DC Brake will activate (refer to P174, P175)</p>
			1 Coast with DC Brake	
			2 Ramp	
			3 Ramp with DC Brake	
P112	Rotation	1	0 Forward Only	If PID mode is enabled, reverse direction is disabled (except for Jog).
			1 Forward and Reverse	

4.5.2 I/O Setup Parameters

Code		Possible Settings			IMPORTANT	
No.	Name	Default	Selection			
P 121	TB-1 Digital Input	0	0 MODE dependent		If P100 = 0 (Local) or = 2 (Network) then P121=0 will have no function. If P100 = 1 (Terminal), then P121 = 0 will function as RUN/STOP.	
			1 STOP (when open, all modes)		When TB1 is asserted, Local modes have no function, Terminal mode has RUN function.	
			2 External Fault FEF		Normally closed circuit; open to trip	
			3 Inverse External Fault FEF		Normally open circuit; close to trip	
			4 Jog Forward		Jog Forward speed = P134	
			5 Jog Reverse		Jog Reverse speed = P135  Active even if P112 = 0	
			6 Preset Speed #1		For frequency mode see P131...P137, For PID mode, see P231...P233, For torque mode see, P331...P333	
			7 DC Brake		Refer to P174; close input to override P175	
			8 Auxiliary Ramp to Stop		Normally closed: Opening input will ramp drive to STOP according to P127, even if P111 is set to Coast (0 or 1).	
			9 Clear Fault		Close to reset fault	
10 Accel/Decel #2		Refer to P125, P126				
	WARNING Jog overrides all STOP commands! To stop the drive while in Jog mode, the Jog input must be deactivated or a fault condition induced.					
	WARNING To use Automatic Restart (power up start), set P110 to a restart setting; P100 = 1 (Terminal mode); P121=1; and assert TB1.					
P 125	Acceleration Time 2	20.0	0.0	{s}	3600	<ul style="list-style-type: none"> Selected using TB-13A...TB-13D (P121...P124 = 17) For S-ramp accel/decel, adjust P106
P 126	Deceleration Time 2	20.0	0.0	{s}	3600	
P 127	Deceleration Time for Auxiliary Ramp to Stop	20.0	0.0	{s}	3600	<ul style="list-style-type: none"> Selected using TB-13A...TB-13D (P121...P124 = 19). For S-ramp accel/decel, adjust P106 Once executed, this ramp time has priority over P105 and P126.
P 129	Automatic Accel/Decel rate switch threshold	0.0	0.0	{Hz}	1000	If Actual Frequency < P129 Use Accel/decel time #2 (P125/P126) If Actual Frequency > P129 Use Accel/decel time #1 (P104/P105)



Commissioning

Code		Possible Settings				IMPORTANT
No.	Name	Default	Selection			
P 131	Preset Speed #1	0.0	0.0	{Hz}	500	• Speed setting is used by P158
P 132	Preset Speed #2	0.0	0.0	{Hz}	500	
P 133	Preset Speed #3	0.0	0.0	{Hz}	500	
P 134	Preset Speed #4	0.0	0.0	{Hz}	500	
P 135	Preset Speed #5	0.0	0.0	{Hz}	500	
P 136	Preset Speed #6	0.0	0.0	{Hz}	500	
P 137	Preset Speed #7	0.0	0.0	{Hz}	500	
P 138	Preset Speed #8	0.0	0.0	{Hz}	500	
P 145	Loss of Load Threshold	0	0	{%}	200	P140, P142 = 10: Output will energize if motor load falls below the P145 value longer than the P146 time
P 146	Loss of Load Delay	0.0	0.0	{s}	240.0	
P 149	Analog Output Offset	0.0	0	{%}	100	Scaled value. Example: P149 = 10%, Scaled variable = freq, P150 = 1, P152 = 60Hz; then TB30 = 0VDC below 6Hz
P 150	TB-30 Output	9	0	None		2-10 VDC signal can be converted to 4-20 mA with a total circuit impedance of 500 Ω
			1	0-10 VDC Output Frequency		
			2	2-10 VDC Output Frequency		
			3	0-10 VDC Load		
			4	2-10 VDC Load		
			5	0-10 VDC Torque		
			6	2-10 VDC Torque		
			7	0-10 VDC Power (kW)		
			8	2-10 VDC Power (kW)		
			9	Network Controlled		
10	Sequencer Controlled		Value set in individual sequencer segments			
P 152	TB-30 Scaling: Frequency	60.0	3.0	{Hz}	2000	If P150 = 1 or 2, sets the frequency at which output equals 10 VDC
P 153	TB-30 Scaling: Load	200	10	{%}	500	If P150 = 3 or 4, sets the Load (as a percent of drive current rating) at which output equals 10 VDC.
P 154	TB-30 Scaling: Torque	100	10	{%}	1000	If P150 = 5 or 6, sets the Torque (as a percent of motor rated torque) at which output equals 10 VDC
P 155	TB-30 Scaling: Power (kW)	1.0	0.1	{kW}	200.0	If P150 = 7 or 8, sets the power at which output equals 10 VDC



4.5.3 Advanced Setup Parameters

Code		Possible Settings			IMPORTANT
No.	Name	Default	Selection		
P 165	Base Voltage		15 {V} 1000		Valid for V/Hz mode only. Set voltage for bus compensation in V/Hz mode
P 166	Carrier Frequency	0	0 4 kHz 1 6 kHz 2 8 kHz 3 10 kHz		<ul style="list-style-type: none"> As carrier frequency is increased, motor noise is decreased Observe derating in section 2.3 Automatic shift to 4 kHz at 120% load NEMA 4X (IP65) Models: Default = 0 (4kHz) NEMA 1 (IP31) Models: Default = 1 (6kHz)
P 167 ⁽¹⁾	Base Frequency	60.0	10.0 {Hz} 1500		
P 168	Fixed Boost		0.0 {%} 40.0		
			NOTE <ul style="list-style-type: none"> P167 = rated motor frequency for standard applications P165, P168 = default setting depends on drive rating 		
P 169	Accel Boost	0.0	0.0 {%} 20.0		Accel Boost is only active during acceleration
P 170	Slip Compensation	0.0	0.0 {%} 40.0		Increase P170 until the motor speed no longer changes between no load and full load conditions.
P 171 ⁽¹⁾	Current Limit	Max I	30 {%} Max I		<ul style="list-style-type: none"> When the limit is reached, the drive displays CL(Current Limit), and either the acceleration time increases or the output frequency decreases. Digital outputs can also indicate when the limit is reached; see P140, P142. Refer to section 2.3 for the maximum output current Max I (%)
P 172	Current Limit Reduction	0	0 Current Limit Reduction Active - Normal response 1 Current Limit Reduction Active - Fast response 2 Current Limit Reduction Disabled - Normal response 3 Current Limit Reduction Disabled - Fast response		In field weakening, the Current Limit is inversely proportional to the speed.
P 173	Decel Override Time	2.0	0.0 {s} 60.0		Maximum time before drive trips into HF fault.
P 174	DC Brake Voltage	0.0	0.0 {%} 50.0		Setting is a percent of the nominal DC bus voltage.
P 175	DC Brake Time	0.0	0.0 {s} 999.9		NOTE: CONFIRM MOTOR SUITABILITY FOR USE WITH DC BRAKING DC Brake voltage (P174) is applied for the time specified by P175 with the following exceptions: <ul style="list-style-type: none"> If P111=1, 3 and P175=999.9 the brake voltage will be applied continuously until a run or fault condition occurs. If P110=2, 4...6 and P175=999.9, brake voltage will be applied for 15s If P121...P124=18 and the corresponding TB-13 input is CLOSED, brake voltage will be applied until the TB-13 input is OPENED or a fault condition occurs.

Commissioning

Code		Possible Settings			IMPORTANT
No.	Name	Default	Selection		
P 176	Keypad Setpoint Single Press Increment	0.1	0.1	100.0	Used for run screen setpoint editing only. If P176 >0.1 then scrolling of keypad setpoint is enabled.
P 178	Display Frequency Multiplier	0.00	0.00	650.00	<ul style="list-style-type: none"> Allows frequency display to be scaled P178 = 0.00: Scaling disabled P178 > 0.00: Display = Actual Frequency X P178
P 179	Run Screen Display	0	0 {Parameter Number}	599	<ul style="list-style-type: none"> 0 = Normal Run Screen, this display depends on mode of operation. Refer to section 4.2. Other selections choose a diagnostic parameter to display (P501...P599). Parameters P560 - P564 are selectable if the sequencer is enabled (P700 is not 0). P560-P564 are not visible until P700 is enabled.
P 180	Oscillation Damping Control	0	0	80	0 = Damping disabled Compensation for resonances within drive
P 181	Skip frequency 1	0.0	0.0 {Hz}	500	<ul style="list-style-type: none"> Drive will not run in the defined skip range; used to skip over frequencies that cause mechanical vibration P181 and P182 define the start of the skip ranges P184 > 0 defines the bandwidth of both ranges.
P 182	Skip frequency 2	0.0	0.0 {Hz}	500	
P 184	Skip frequency bandwidth	0.0	0.0 {Hz}	10.0	
					
P 185	Voltage Midpoint V/Hz characteristic	0	0.0 {V}	P165	Valid only when P300 = 0 or 2. Use with P187 to define midpoint on V/Hz curve.
P 187 ⁽²⁾	Frequency Midpoint V/Hz characteristic	0.0	0.0 {Hz}	P167	Valid only when P300 = 0 or 2. Use with P185 to define midpoint on V/Hz curve.
P 190	Motor Braking		0 Disabled		Flux brake OFF.
			1 Braking with BUS threshold		When drive is in deceleration and $V_{bus} > V_{deceleration\ freeze}$ (114% of the rated V_{bus}), the flux brake will be turned ON.
			2 Braking always on with deceleration		As long as drive is in deceleration, the flux brake will be ON.
			3 Braking with bus regulator		When drive is in deceleration and $V_{bus} > V_{deceleration\ freeze}$ (114% of the rated V_{bus}), the motor speed will be increased to reduce the bus voltage. Determined by the value in P191, the speed increment = slip speed * P191(%) / 37.
			4 Special		(Consult factory before using)
	WARNING Flux braking can cause heat in the motor. To avoid damage to the motor, use a PTC to protect the motor. If the flux brake is used too frequently, the drive will trip fault "F_PF".				
P 191	Motor Brake Level	0	0 (%)	75	Active when P190 > 0 and drive is in deceleration mode. Use to reduce deceleration time on high inertia loads. NOTE: Over usage of P190 can cause frequent 'overload' trips "F.PF" Not active for P300 = 5 (Torque mode)



Commissioning

Code		Possible Settings		IMPORTANT
No.	Name	Default	Selection	
P 192	Motor Braking Deceleration Reduction Level	0.0	0 (base freq) P167 Raising the value of P191 reduces the drive deceleration rate during flux braking.	Active when P190 > 0 and P192 > 0.0, Drive is in deceleration mode. Use to reduce deceleration time on high inertia loads. NOTE: Usage of P192 can cause the drive to decelerate faster than settings in P105/P127. Not active for P300 = 5 (Torque mode)
P 194	Password	0	0000 9999	<ul style="list-style-type: none"> Must enter password to access parameters P194 = 0000: Disables password
P 197	Clear Fault History	0	0 No Action 1 Clear Fault History	
P 199	Program Selection		0 Operate from User settings 1 Operate from OEM settings 2 Reset to OEM default settings 3 Reset to 60 Hz default settings 4 Reset to 50 Hz default settings 5 Translate	Refer to Notes 1, 2 and 3 Refer to Note 1 <ul style="list-style-type: none"> Refer to Note 4 Parameters are reset to the defaults listed in this manual. For P199=4, the following exceptions apply: <ul style="list-style-type: none"> - P103, P152, P161, P167 = 50.0 Hz - P165 = 400V (400/480V drives only) - P304 = 50 Hz - P305 = 1450 RPM - P107 = 0 (480 V drives only) Refer to Note 5
			WARNING! Modification of P199 can affect drive functionality! STOP and EXTERNAL FAULT circuitry may be disabled! Check P100 and P121...P124	
			NOTE 1 If the EPM does not contain valid OEM settings, a flashing GF will be displayed when P199 is set to 1 or 2. NOTE 2 When P199 is set to 1, the drive operates from the OEM settings stored in the EPM Module and no other parameters can be changed (CE will be displayed if attempted). NOTE 3 Auto Calibration is not possible when operating from OEM Settings. NOTE 4 Resetting to 50 and 60 Hz default settings will set the Assertion Level (P120) to "2" (High). P120 may need to be reset for the digital input devices being used. An F.AL fault may occur if P120 and the Assertion switch are not set identically. NOTE 5 If an EPM that contains data from a previous compatible software version is installed: <ul style="list-style-type: none"> The drive will operate according to the previous data, but parameters cannot be changed (CE will be displayed if attempted) To update the EPM to the current software version, set P199 = 5. The parameters can now be changed but the EPM is incompatible with previous software revisions. 	

(1) Any changes to this parameter will not take effect until the drive is stopped.

Commissioning

4.5.4 PID Parameters

Code		Possible Settings			IMPORTANT	
No.	Name	Default	Selection			
P200	PID Mode	0	0	Disabled	<ul style="list-style-type: none"> Normal-acting: As feedback increases, motor speed decreases Reverse-acting: As feedback increases, motor speed increases PID mode is disabled in Vector Torque mode (P300 = 5) Selections 3, 4: If P112=1, PID controller output sets the speed, (range -max freq to +max freq) 	
			1	Normal-acting		
2	Reverse-acting					
3	Normal-acting, Bi-directional					
4	Reverse-acting, Bi-directional					
			NOTE To activate PID mode, one of the TB-13 inputs (P121...P124) must be used to select the Auto Reference that matches the desired PID setpoint reference. If the selected PID setpoint reference uses the same analog signal as the PID feedback (P201), an F..I L fault will occur. Example: The desired PID setpoint reference is the keypad (▲ and ▼). Set TB-13x = 6 (Auto Reference: Keypad): <ul style="list-style-type: none"> TB-13x = closed: PID mode is active TB-13x = open: PID mode is disabled and the drive speed will be controlled by the reference selected in P101. 			
P201	PID Feedback Source	0	0	4-20 mA (TB-25)	Must be set to match the PID feedback signal	
			1	0-10 VDC (TB-5)		
			2	Drive Load (P507)		
			3	Feedback from Network		
P202	PID Decimal Point	1	0	PID Display = XXXX	Applies to P204, P205, P214, P215, P231... P233, P242, P522, P523	
			1	PID Display = XXX.X		
			2	PID Display = XX.XX		
			3	PID Display = X.XXX		
P203 (2)	PID Units	0	0	%	Select the UNITS LED that will be illuminated when the drive is running in PID control mode	
			1	/UNITS		
			2	AMPS		
			3	NONE		
P204	Feedback at Minimum Signal	0.0	-99.9	3100.0	Set to match the range of the feedback signal being used	
P205	Feedback at Maximum Signal	100.0	-99.9	3100.0	Example: Feedback signal is 0 - 300 PSI; P204 = 0.0, P205 = 300.0	
P207	Proportional Gain	5.0	0.0	{%}	Used to tune the PID loop: <ul style="list-style-type: none"> Increase P207 until system becomes unstable, then decrease P207 by 10-15% Next, increase P208 until feedback matches setpoint If required, increase P209 to compensate for sudden changes in feedback 	
P208	Integral Gain	0.0	0.0	{s}		
P209	Derivative Gain	0.0	0.0	{s}		
			NOTE <ul style="list-style-type: none"> Derivative Gain is very sensitive to noise on the feedback signal. Use with care. Derivative Gain is not normally required in pump and fan applications 			
P210	PID Setpoint Ramp	20.0	0.0	{s}	100.0	<ul style="list-style-type: none"> time of setpoint change from P204 to P205 or vice versa. Used to smooth the transition from one PID setpoint to another, such as when using the Preset PID Setpoints (P231...P233)
P214	Minimum Alarm	0.0	P204	P205	Use with P140, P142 = 18...23	
P215	Maximum Alarm	0.0	P204	P205		
P231	Preset PID Setpoint #1	0.0	P204	P205	TB-13A activated; P121 = 3 and P200 = 1 or 2	

Commissioning

Code		Possible Settings			IMPORTANT
No.	Name	Default	Selection		
P232	Preset PID Setpoint #2	0.0	P204	P205	TB-13B activated; P122 = 3 and P200 = 1 or 2
P233	Preset PID Setpoint #3	0.0	P204	P205	TB-13C activated; P123 = 3 and P200 = 1 or 2
P234	Preset PID Setpoint #4	0.0	P204	P205	TB-13D activated; P124 = 3 and P200 = 1 or 2
P240	Sleep Threshold	0.0	0.0	{Hz} 500.0	<ul style="list-style-type: none"> If drive speed < P240 for longer than P241, output frequency = 0.0 Hz; drive display = SLP P240 = 0.0: Sleep mode is disabled. P200 = 0...2: Drive will start again when speed command is above P240 P242 > 0.0: Drive will restart when the PID feedback differs from the setpoint by more than the value of P242 or when the PID loop requires a speed above P240.
P241	Sleep Delay	30.0	0.0	{s} 300.0	
P242	Sleep Bandwidth	0.0	0.0	B_{max}	
			Where: $B_{max} = (P205 - P204) $		
P243	Feedback Sleep Entry Threshold	0.0	P204	P205	Active only when P244 = 1 or 2
P244	Sleep Entry Mode	0	0 Enter SLEEP if Drive Speed < P240 1 Enter SLEEP if Feedback > P243 2 Enter SLEEP if Feedback < P243		For time longer than P241 For time longer than P241 or same as Sel 0 For time longer than P241 or same as Sel 0
P245	Sleep Entry Stop Type	0	0 Coast to Stop 1 Ramp to Stop 2 Stop with P111 settings		
P246	Feedback Recovery from Sleep Threshold	0.0	P204	P205	Active only when P247 = 1 or 2
P247	Sleep Recovery Mode	0	0 Recovery if Speed Setpoint > P240 or if PID feedback differs from setpoint by more than P242 1 Recovery only if Feedback < P246 2 Recovery only if Feedback > P246		
P250	Auto Rinse in Sleep Mode	0	0 Disabled 1 Enabled		Activated in sleep mode only. Sleep Recovery cancels Auto Rinse
P251	Time Delay between Auto Rinses	30.0	0.0	{min} 6553.5	Time delay reset by re/entering sleep mode
P252	Auto Rinse Speed	0.0	-500.0	{Hz} 500.0	If P112 = 1, negative sign = reverse direction
P253	Auto Rinse Time	0.0	0.0	{sec} 6553.5	Does not include time to decel back to speed
			Auto Pump Rinse Setup: P250=1 (Enabled) P251=# minutes between each Pump Rinse P252=Hz speed of Pump Rinse P253=# seconds Pump Rinse duration		
P280	Current Level: Flying Restart Type 2	70.0	0.0	{%} P171	Maximum current during Type 2 flying restart operation
P281	Decel Time: Flying Restart Type 2	3.0	0.0	{sec} 3600.0	Deceleration rate used during Type 2 flying restart operation

Commissioning

4.5.5 Vector Parameters





Code		Possible Settings		IMPORTANT
No.	Name	Default	Selection	
P300 ⁽¹⁾	Drive Mode	1	0 Constant V/Hz	Constant torque V/Hz control for general applications
			1 Variable V/Hz	Variable torque V/Hz control for centrifugal pump and fan applications
			2 Enhanced Constant V/Hz	For single or multiple motor applications that require better performance than settings 0 or 1, but cannot use Vector mode, due to:
			3 Enhanced Variable V/Hz	
			4 Vector Speed	For single-motor applications requiring higher starting torque and speed regulation
			5 Vector Torque	For single-motor applications requiring torque control independent of speed
		 NOTE To configure the drive for either Vector mode or Enhanced V/Hz mode:		
			<ul style="list-style-type: none"> P300 = 4, 5: <ul style="list-style-type: none"> Set P302...P306 according to motor nameplate Set P399 = 1 or 2 (if option 1 failed or in case of non-standard motor) Make sure motor is cold (20° - 25° C) and apply a Start command Display will indicate CAL for about 40 seconds Once the calibration is complete, the display will indicate Stop; apply another Start command to actually start the motor If an attempt is made to start the drive in Vector or Enhanced V/Hz mode before performing the Motor Calibration, the drive will display F.n1d and will not operate P300 = 2, 3: Same as above but only need to set P302...P304 	
P302 ⁽¹⁾	Motor Rated Voltage		0 {V} 600	<ul style="list-style-type: none"> Default setting = drive rating Set to motor nameplate data
P303 ⁽¹⁾	Motor Rated Current		0.1 {A} 500.0	
P304 ⁽¹⁾	Motor Rated Frequency	60	0 {Hz} 1000	Set to motor nameplate data
P305 ⁽¹⁾	Motor Rated Speed	1750	300 {RPM} 65000	
P306 ⁽¹⁾	Motor Cosine Phi	0.80	0.40 0.99	
		 NOTE If motor cosine phi is not known, use one of the following formulas: $\cos \phi = \text{motor Watts} / (\text{motor efficiency} \times P302 \times P303 \times 1.732)$ $\cos \phi = \cos [\sin^{-1} (\text{magnetizing current} / \text{motor current})]$		
P310 ⁽¹⁾	Motor Stator Resistance		0.00 {Ω} 64.00	<ul style="list-style-type: none"> P310, 311 default setting depends on drive rating Will be automatically programmed by P399 Changing these settings can adversely affect performance. Contact factory technical support prior to changing
P311 ⁽¹⁾	Motor Stator Inductance		0.0 {mH} 2000	
P315	Dead Time Compensation Factor	0.0	-50.0 {‰} +50.0	<ul style="list-style-type: none"> Adjust dead time correction from internal default Takes effect when P399 = 3.
P330	Torque Limit	100	0 {‰} 400	When P300 = 5, sets the maximum output torque.
P331	Preset Torque Setpoint #1	100	0 {‰} 400	TB-13A activated; P121 = 3 and P300 = 5
P332	Preset Torque Setpoint #2	100	0 {‰} 400	TB-13B activated; P122 = 3 and P300 = 5
P333	Preset Torque Setpoint #3	100	0 {‰} 400	TB-13C activated; P123 = 3 and P300 = 5

Commissioning

Code		Possible Settings				IMPORTANT
No.	Name	Default	Selection			
P334 (2)	Preset Torque Setpoint #4	100	0	{%}	400	TB-13D activated; P124 = 3 and P300 = 5
P340 (1)	Current Loop P Gain	0.25	0.00		16.0	Changing these settings can adversely affect performance. Contact factory technical support prior to changing.
P341 (1)	Current Loop I Gain	65	12	{ms}	9990	
P342 (1)	Speed Loop Adjust	0.0	0.0	{%}	20.0	
P343	Slip Compensation Response Filter	99	90	{ms}	9999	Low pass filter time constant for varying the slip compensation response to changes in the motor current.
P399	Motor Auto-calibration	0	0 Calibration Not Done			<ul style="list-style-type: none"> • If P300 = 4 or 5, motor calibration must be performed if P399 is not set to 3 (bypass calibration). • If P300=2 or 3, motor calibration is recommended. • Use option 2 if option 1 failed or in case of non-standard motors • An alternating CAL / Err will occur if: <ul style="list-style-type: none"> - attempt motor calibration with P300 = 0 or 1 - motor calibration is attempted before programming motor data
			1 Standard Calibration Enabled			
2 Advanced Calibration Enabled						
3 Bypass Calibration, enable operation in vector mode w/o Auto Calibration						
4 Standard Calibration Complete						
5 Advanced Calibration Complete						
			NOTE: To run the Auto Calibration: <ul style="list-style-type: none"> - Set P302...P306 according to motor nameplate - Set P399 = 1 or 2 (if option 1 failed or in case of non-standard motor) - Make sure motor is cold (20° - 25° C) - Apply a Start command - Display will indicate CAL for about 40 seconds - Once the calibration is complete, the display will indicate Stop; apply another Start command to actually start the motor - Parameter P399 will now be set to 4 or 5. 			

Commissioning

4.5.6 Network Parameters

Code		Possible Settings		IMPORTANT
No.	Name	Default	Selection	
P400	Network Protocol	2	0 Not Active	This parameter setting is based upon the network or I/O module that is installed.
			1 Remote Keypad	
			2 Modbus RTU	
			3 CANopen	
			4 DeviceNet	
			5 Ethernet	
			6 Profibus	
			7 Lecom-B	
			8 I/O Module	
P403	Module Reset	0	0 No Action	Transition 0 -> 1 activates Modbus related settings in P410, P411, P412 Value automatically returns to 0
			1 Activate Modbus related settings	
P405	Current Network Fault	0	0 No Fault	Network triggered fault by writing into register 2107
			1 F.nF1	
			2 F.nF2	
			3 F.nF3	
			4 F.nF4	
			5 F.nF5	
			6 F.nF6	
			7 F.nF7	
			8 F.nF8	
			9 F.nF9	Overall I/O Message Timeout
P410	Network Address	11	1 - 247	Modbus Node address. After modification, activate with P403
P411	Network Baud Rate	3	0 2400 bps	After modification, activate with P403
			1 4800 bps	
			2 9600 bps	
			3 19200 bps	
			4 38400 bps	
			5 57600 bps	
			6 115200 bps	
P412	Network Data Format	2	0 8, N, 2	After modification, activate with P403
			1 8, N, 1	
			2 8, E, 1	
			3 8, O, 1	
P420	Network Timeout Action	1	0 No action	Active when drive is in network control mode.(Register 2100, bit 5 set) Sets the reaction to network faults caused by network timeout or direct writing into the network fault register 2007.
			1 Stop (P111)	
			2 Quick Stop	
			3 Controller Inhibit	
			4 Trip Fault, F.ntF	
P421	Network Timeout	15.0	0.0 {sec} 300.0	
P430	Display Override	3.0	0.0 {sec} 10.0	
P470	Network Messages Received	0	0 9999 (Read only)	Valid Network messages received.
			NOTE: When the number of messages exceeds 9999, the counter resets and resumes counting from 0.	
P471	Network Messages Transmitted	0	0 9999 (Read only)	Messages transmitted by the drive.
			NOTE: When the number of messages exceeds 9999, the counter resets and resumes counting from 0.	
P498	Modbus Messages with Exception	0	0 9999 (Read only)	Modbus messages generating exception responses.
			NOTE: When the number of messages exceeds 9999, the counter resets and resumes counting from 0.	
P499	Invalid Modbus Messages	0	0 9999 (Read only)	Invalid Messages received by the drive.
			NOTE: When the number of messages exceeds 9999, the counter resets and resumes counting from 0.	

4.5.7 Diagnostic Parameters

Code		Display Range (READ ONLY)		IMPORTANT
No.	Name			
P500	Fault History			<ul style="list-style-type: none"> Displays the last 8 faults Format: n.xxx where: n = 1..8, 1 is the newest fault; xxx = fault message (w/o the F) Refer to section 5.3
P501	Software Version			Format: xyz
P502	Drive ID			A flashing display indicates that the Drive ID stored in the EPM does not match the drive model it is plugged into.
P503	Internal Code			Alternating Display: xxx-; -yy
P505	DC Bus Voltage	0	{VDC} 1500	
P506	Motor Voltage	0	{VAC} 1000	
P507	Load	0	{%} 255	Motor load as % of drive's output current rating. Refer to section 2.3.
P508	Motor Current	0.0	{A} 1000	Actual motor current
P509	Torque	0	{%} 500	Torque as % of motor rated torque (vector mode only)
PS10	Output Power kW	0.00	{kW} 650.0	
PS11	Total kWh	0.0	{kWh} 9999999	Alternating display: xxx-; yyyy when value exceeds 9999
PS12	Heatsink Temp	0	{°C} 150	Heatsink temperature
P520	0-10 VDC Input	0.0	{VDC} 10.0	Actual value of signal at TB-5 (See P162)
P521	4-20 mA Input	0.0	{mA} 20.0	Actual value of signal at TB-25 (See P162)
P522	TB-5 Feedback	P204	P205	TB-5 signal value scaled to PID feedback units (See P162)
P523	TB-25 Feedback	P204	P205	TB-25 signal value scaled to PID feedback units (See P162)
P524	Network Feedback	P204	P205	Network signal value scaled to PID feedback units
P525	Analog Output	0	{VDC} 10.0	Refer to P150...P155
P527	Actual Output Frequency	0	{Hz} 500.0	
P528	Network Speed Command	0	{Hz} 500.0	Command speed if (Auto: Network) is selected as the speed source
P530	Terminal and Protection Status			Indicates terminal status using segments of the LED display. (Refer to section 4.5.7.1)
P531	Keypad Status			Indicates keypad button status using segments of the LED display. (Refer to section 4.5.7.2)
P540	Total Run Time	0	{h} 9999999	Alternating display: xxx-; yyyy when value exceeds 9999
P541	Total Power On Time	0	{h} 9999999	
P550	Fault History	1	8	<ul style="list-style-type: none"> Displays the last 8 faults Format: n.xxx where: n = 1..8, 1 is the newest fault; xxx = fault message (w/o the F) Refer to section 5.3
P551	Fault History Time	0	{h} 999999	Display: "n.hh-" "hhhh" "mm.ss" = fault #, hours, seconds The "hhhh" screen is displayed after hours exceed 999.
P552	Fault History Counter	0	255	Number of sequential occurrences of a fault. For example: 3 external faults occur over a period of time with no other errors occurring. Then P552 will indicate 3, P550 will indicate the error EF and P551 will indicate the time of the first fault occurrence.

Commissioning

4.5.7.1 Terminal & Protection Status Display

Parameter P530 allows monitoring of the control terminal points and common drive conditions:

An illuminated LED segment indicates:

- the protective circuit is active (LED 1)
- the Logic Assertion Switch is set to High (+)
- input terminal is asserted (LED 2)
- output terminal is energized (LED 4)
- the Charge Relay is not a terminal, this segment will be illuminated when the Charge Relay is energized (LED 4).

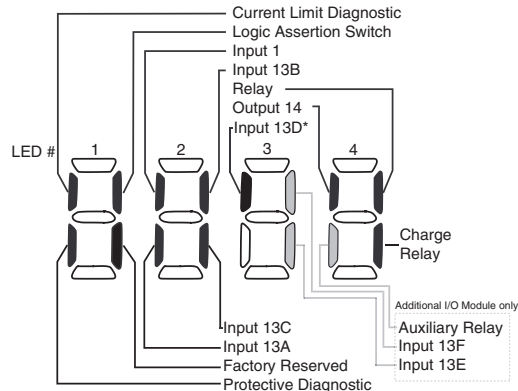

* Input 13D available on 15-60HP (11-45kW) models only

4.5.7.2 Keypad Status Display

Parameter P531 allows monitoring of the keypad pushbuttons:

An illuminated LED segment indicates when the button is depressed.

LED 1 and LED 2 are used to indicate pushbutton presses on a remote keypad that is attached to the drive. LED 3 and LED 4 indicate button presses on the local drive keypad.

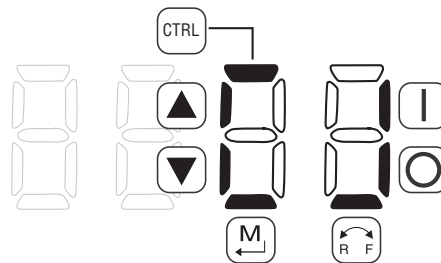

4.5.8 Custom Modbus Instructions for ESVxxxNxxxXB571 models

Control scheme, new register area and control word has been implemented.

Legacy control scheme utilizing: writing to special registers 48 and 49 to 'unlock' control and parameters is not supported any more in these drives. Legacy control register is no longer supported as well. Requirement for one of the digital input terminals to be asserted with its selection set to 'Network Enabled' has been removed.

To simplify access and control, new register area has been implemented starting at reg. address 2000. In this special range, multiple registers access is supported.

Automatic Restarts (power up starts) are working only if P110 is set to one of the restarts settings and: P100 = 1 (Terminal mode); P121 = 0 or 1; and terminal Tb1 is asserted.

Modbus Reg.	Name	Access Type	Range of adjustment	Important
2000	Drive Status Word	Read only	0 – 0xFFFF	
	See bit details below			
2001	Actual Frequency	Read only	0 – 65535 [0.1Hz]	Resolution 0.1Hz (ex. 345 – 34.5Hz)
2002	Drive Fault Code	Read only	0-255	See details below
2003	Drive State	Read only	0 – 255	See details below
2004	Motor Voltage	Read only	0 – 1000 [VAC]	RMS voltage applied to Motor (P506)
2005	Motor Current	Read only	0-1000 [0.1A]	Motor phase current (P508)

Commissioning

Modbus Reg.	Name	Access Type	Range of adjustment	Important
2006	Drive Load	Read only	0-255 [%]	Motor load as % of drive's output current rating (P507)
2007	Output Power	Read only	0-655.00 [0.01 KW]]	
2008	Heatsink Temperature	Read only	0-150 [°C]	
2009	DC Bus Voltage	Read only	0-1500 [VDC]	
2010	Digital Inputs	Read only	Word representing misc. binary statuses	See reference below
2011	Actual Torque	Read only	0-500%	Torque as % of motor rated torque (vector mode only)
2012	Actual Setpoint Frequency	Read only	0 – 65535 [0.1Hz]	Resolution 0.1Hz (ex. 345 – 34.5Hz)
2013	Reserved	Read only	0 – 0xFFFF	
2014	Reserved	Read only	0 – 0xFFFF	
2015	Reserved	Read only	0 – 0xFFFF	
2016	Reserved	Read only	0 – 0xFFFF	
2017	Reserved	Read only	0 – 0xFFFF	
2018	Reserved	Read only	0 – 0xFFFF	
2100	Drive Control Word	Read/Write	0 – 0xFFFF	
	See bit details below			
2101	Network Frequency Setpoint	Read/Write	0 – 65535 [0.1Hz]	Resolution 0.1Hz (ex. 345 – 34.5Hz)
2102	Network Analog Output	Read/Write	0 – 1000 [0.01 VDC]	Sets the output voltage level at terminal Tb30. P150 must be set to 9 'Network Control'
2103	Digital/Relay Output	Read/Write	Reserved	Reserved – User controlled digital output and relay are not available
2104	Network PID Setpoint	Read/Write	P204...P205	Min/max user feedback scaling Signed Feedback Display Units
2105	Network PID Feedback Reference	Read/Write	P204...P205	Min/max user feedback scaling Signed Feedback Display Units
2106	Network Torque Setpoint	Read/Write	0-100%	
2107	Trigger Network Fault	Read/Write	0-9	Writing into this register triggers drive fault 'F.Fn1...9. To clear it, first write 9 into this register.
2108	Override Display Dig 1 and 2	Read/Write	0-0xFFFF	High byte represents the 8 LED segments of digit 1 of Drive display. Low byte represents the 8 LED segments of digit 2 of Drive display.
2109	Override Display Dig 2 and 3	Read/Write	0-0xFFFF	High byte represents the 8 LED segments of digit 3 of Drive display. Low byte represents the 8 LED segments of digit 4 of Drive display. After writing this register (2009), if both values in reg. 2108 and 2109 are not equal 0 the Drive display will switch to display the override value. See note below with example.
2110	Reserved	Read/Write	0-0xFFFF	

Commissioning

4.5.8.1 Register 2000 - Drive Status Word

Register 2000 - Drive Status Word		
Bit	Description	
0	1 = Faulted	
1	Reserved	
2	1 = Running Forward	
3	1 = Running Reverse	
4	1 = Ready	
5	0 = Local Control 1 = Control from Network	
6	0 = Local reference 1 = Reference from Network	
7	1 = At reference	
8	Actual set point source: 0 – keypad 1 – 0-10VDC 2 – 4-20mA 3 – Preset #1 4 – Preset #2 5 – Preset #3 6 – Preset #4 7 – Preset #5 8 – Preset #6 9 – Preset #7 10 – MOP 11 – Network	
9		
10		
11		
12		1 = PID Active (closed loop)
13		1 = Torque mode active
14		1 = Current limit
15		1 = DC Braking

4.5.8.2 Register 2002 - Drive Fault

Register 2002 - Drive Fault					
Fault #	Description	Fault #	Description	Fault #	Description
0	No Fault	15	Start Fault	30	Internal #11
1	IGBT Temperature Fault	16	Incompatible Parameter Set	31	Internal #12
2	Output Fault	17	EPM Hardware Fault	32	Internal #13
3	Ground Fault	18	Internal #1	33	Internal #14
4	Temperature Fault	19	Internal #2	34	Comm. Module Failure
5	Flying Start Fault	20	Internal #3	35	Network Fault
6	High DC BUS	21	Internal #4	36	Network Fault #1
7	Low DC BUS	23	Internal #6	37	Network Fault #2
8	Overload Fault	24	Internal #7	38	Network Fault #3
9	OEM Fault	25	Internal #8	39	Network Fault #4
10	Illegal Setup Fault	26	Internal #9	40	Network Fault #5
11	Dynamic Brake Fault	27	Internal #10	41	Network Fault #6
12	Phase Lost	28	Remote Keypad Lost	42	Network Fault #7
13	External Fault	29	Assertion Level Fault	43	Network Fault #8
14	Control Fault			44	Network Fault #9

4.5.8.3 Register 2003 - Drive State

Register 2003: Drive Status	
Status Number	Description
0	Fault Locked
1	Fault
2	Start Pending
3	Identification Not done
4	Stop - Inhibit
5	Stop
6	Switching On Sequence
7	Identification in Process
8	Running
9	Acceleration
10	Deceleration
11	Deceleration Override
12	DC Brake
13	Flying start
14	Slow Current Limit
15	Fast Current Limit
16	Sleep mode

4.5.8.4 Register 2010 - Digital Inputs

Register 2010: Digital Inputs	
Status Number	Description
0	
1	
2	Output Fault
3	Fast Current Limit State
4	TB1 ON
5	
6	TB13A
7	TB13B
8	TB13C
9	TB14 Out State
10	Relay State
11	Charge Relay
12	Assertion level
13	
14	
15	
16	

Commissioning

4.5.8.5 Register 2100 - Network Control Word

Register 2100 - Network Control Word	
Bit	Description
0	0 = NOT Run Forward 1 = Run Forward
1	0 = NOT Run Reverse 1 = Run Reverse
2	Fault reset on transition from 0 to 1
3	Reserved
4	Reserved
5	0 = Local Control 1 = Network Control *This Bit MUST be set for the drive to start/stop from Modbus*
6	0 = Local Speed reference 1 = Network Speed reference *This Bit MUST be set for the drive to accept speed from Modbus*
7	Reserved
8	Network Speed reference (valid when bit 6 set)
9	0 – Network
10	1 – keypad
11	2 – 0-10VDC
	3 – 4-20mA
	4 – Preset #1
	5 – Preset #2
	6 – Preset #3
	7 – Preset #4
	8 – Preset #5
	9 – Preset #6
	10 – Preset #7
	11 – MOP
12	0 = No Action 1 = Inhibit (Coast to STOP)
13	0 = No Action 1 = Activate Quick STOP
14	0 = No Action 1 = Force Manual Mode (active only in Network Control, in PID mode will force open loop)
15	0 = DC brake active 1 = DC brake NOT active

Example of usage: To start the drive write into register 2100 value 0x0061. Since Network reference is set as well (bit6 = 1), writing into reg. 2101 frequency setpoint will take effect as well.

4.5.8.6 Registers 2108 and 2109 - Drive Display Override

Register	Byte	Description
2108	High Byte	Display LED Digit 1 – number represents 7 segments+ decimal point
	Low Byte	Display LED Digit 2 – number represents 7 segments+ decimal point
2109	High Byte	Display LED Digit 3 – number represents 7 segments+ decimal point
	Low Byte	Display LED Digit 4 – number represents 7 segments+ decimal point

Encoding of LED segments:

- Segment A – bit 0
- Segment B – bit 1
- Segment C – bit 2
- Segment D – bit 3
- Segment E – bit 4
- Segment F – bit 5
- Segment G – bit 6
- Segment H – bit 7

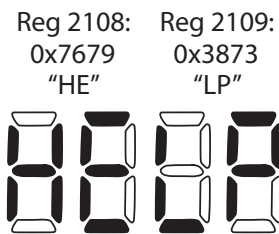
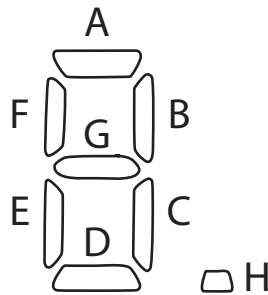

Example: letter 'H' – encoded as 0x76

To display word: 'HELP' – write following values: to register 2108 -> 0x7679 ('HE'), and to register 2109 -> 0x3873 ('LP').

Once register 2109 is written display will switch to new value. To switch off display override, write 0x0000 into registers 2108 and 2109, or drive will return to its normal display after time period set in P430. To maintain the 'override' display, register 2109 must be re-written periodically – faster than P430.

Troubleshooting and Diagnostics

5 Troubleshooting and Diagnostics

5.1 Status/Warning Messages

Status / Warning		Cause	Remedy
br	DC-injection brake active	DC-injection brake activated <ul style="list-style-type: none"> activation of digital input (P121 = 7) automatically (P110 = 2, 4...6) automatically (P111 = 1, 3) 	Deactivate DC-injection brake <ul style="list-style-type: none"> deactivate digital input automatically after P175 time has expired
bF	Drive ID warning	The Drive ID (P502) stored on the EPM does not match the drive model.	<ul style="list-style-type: none"> Verify motor data (P302...P306) and perform Auto Calibration. Set drive mode (P300) to 0 or 1 Reset the drive (P199 to 3 or 4) and reprogram.
CAL	Motor Auto-calibration active	Refer to P300, P399	Motor Auto-calibration is being performed
cE	An EPM that contains valid data from a previous software version has been installed	An attempt was made to change parameter settings	Parameter settings can only be changed after the EPM data is converted to the current version (P199 = 5)
CL	Current Limit (P171) reached	Motor overload	<ul style="list-style-type: none"> Increase P171 Verify drive/motor are proper size for application
dEC	Decel Override	The drive has stopped decelerating to avoid tripping into HF fault, due to excessive motor regen (2 sec max).	If drive trips into HF fault: <ul style="list-style-type: none"> Increase P105, P126 Install Dynamic Braking option
Err	Error	Invalid data was entered, or an invalid command was attempted	
FCL	Fast Current Limit	Overload	Verify drive/motor are proper size for application
FSt	Flying Restart Attempt after Fault	P110 = 5,6	
GE	OEM Settings Operation warning	An attempt was made to change parameter settings while the drive is operating in OEM Settings mode.	In OEM Settings mode (P199 = 1), making changes to parameters is not permitted.
GF	OEM Defaults data warning	An attempt was made to use (or reset to) the OEM default settings (P199 = 1 or 2) using an EPM without valid OEM data.	Install an EPM containing valid OEM Defaults data
LC	Fault Lockout	The drive attempted 5 restarts after a fault but all attempts were unsuccessful (P110 = 3...6)	<ul style="list-style-type: none"> Drive requires manual reset Check Fault History (P500) and correct fault condition
PdEC	PID Deceleration Status	PID setpoint has finished its ramp but the drive is still decelerating to a stop.	
PI d	PID Mode Active	Drive has been put into PID Mode.	Refer to P200
SLP	Sleep Mode is active	Refer to P240...P242	
SP	Start Pending	The drive has tripped into a fault and will automatically restart (P110 = 3...6)	To disable Auto-Restart, set P110 = 0...2
SPd	PID Mode disabled.	Drive has been taken out of PID Mode. Refer to P200.	
StoP	Output frequency = 0 Hz (outputs U, V, W inhibited)	Stop has been commanded from the keypad, terminal strip, or network	Apply Start command (Start Control source depends on P100)

Troubleshooting and Diagnostics

5.2 Drive Configuration Messages

When the Mode button is pressed and held, the drive's display will provide a 4-digit code that indicates how the drive is configured. If the drive is in a Stop state when this is done, the display will also indicate which control source commanded the drive to Stop (the two displays will alternate every second).

Configuration Display			
Format = x.y.zz	x = Control Source: L = Local Keypad t = Terminal Strip r = Remote Keypad n = Network	y = Mode: S = Speed mode P = PID mode t = Torque mode C = Sequencer mode	zz = Reference: CP = Keypad ▲ ▼ EU = 0-10 VDC (TB-5) E I = 4-20 mA (TB-25) JG = Jog nt = Network OP = MOP P 1...P7 = Preset 1...7 Q 1...16 = Sequencer Segment
	Example: L.S.CP = Local Keypad Start control, Speed mode, Keypad speed reference t.p.EU = Terminal Strip Start control, PID mode, 0-10 VDC setpoint reference t.C.12 = Terminal Strip Start control, Sequencer Operation (Speed mode), Segment #12 n.t.p2 = Network Start control, Vector Torque mode, Preset Torque #2 reference n.S.03 = Network Start control, Speed mode, Speed reference from Sequencer segment #03		
Stop Source Display			
Format = x_5tP	L_5tP = Stop command came from Local Keypad t_5tP = Stop command came from Terminal Strip r_5tP = Stop command came from Remote Keypad n_5tP = Stop command came from Network		

Troubleshooting and Diagnostics

5.3 Fault Messages

The messages below show how they will appear on the display when the drive trips. When looking at the Fault History (P500), the **F_** will not appear in the fault message.

Fault		Cause	Remedy ⁽¹⁾
F_AF	High Temperature fault	Drive is too hot inside	<ul style="list-style-type: none"> Reduce drive load Improve cooling
F_AL	Assertion Level fault	<ul style="list-style-type: none"> Assertion Level switch is changed during operation P120 is changed during operation P100 or P121 is set to a value other than 0 and P120 does not match the Assertion Level Switch. 	<ul style="list-style-type: none"> Make sure the Assertion Level switch and P120 are both set for the type of input devices being used, prior to setting P100 or P121. Refer to 3.2.3 and P120.
F_bF	Personality fault	Drive Hardware	<ul style="list-style-type: none"> Cycle Power Power down and install EPM with valid data Reset the drive back to defaults (P199 = 3, 4) and then re-program If problem persists, contact factory technical support
F_cF	Control fault	An EPM has been installed that is either blank or corrupted	
F_cF	Incompatible EPM fault	An EPM has been installed that contains data from an incompatible parameter version	
F_cFt	Forced Translation fault	An EPM from an old drive put in new drive causes drive to trip F_cFT fault.	Press [M] (mode button) twice to reset
F_dbF	Dynamic Braking fault	Dynamic braking resistors are overheating	<ul style="list-style-type: none"> Increase active decel time (P105, P126, P127). Check mains voltage and P107
F_EF	External fault	<ul style="list-style-type: none"> P121 = 2 and that digital input has been opened. P121 = 3 and that digital input has been closed. 	<ul style="list-style-type: none"> Correct the external fault condition Make sure digital input is set properly for NC or NO circuit
F_F I	EPM fault	EPM missing or defective	Power down and replace EPM
F_F2 ... F_F I2	Internal faults		Contact factory technical support
F_Fnr	Control Configuration Fault		
F_FoL	TB25 (4-20 mA signal) Threshold fault	4-20 mA signal (at TB-25) drops below the value set in P164.	<ul style="list-style-type: none"> Check signal/signal wire Refer to parameters P163 and P164.
F_GF	OEM Defaults data fault	Drive is powered up with P199 = 1 and OEM settings in the EPM are not valid.	Install an EPM containing valid OEM Defaults data or change P199 to 0.
F_HF	High DC Bus Voltage fault	Mains voltage is too high	Check mains voltage and P107
		Decel time is too short, or too much regen from motor	Increase active decel time (P105, P126, P127) or install Dynamic Braking option
F_IL	Digital Input Configuration fault (P121)	More than one digital input set for the same function	Each setting can only be used once (except settings 0 and 3)
		Only one digital input configured for MOP function (Up, Down)	One input must be set to MOP Up, another must be set to MOP Down
		PID mode is entered with setpoint reference and feedback source set to the same analog signal	Change PID setpoint reference (P121...P124) or feedback source (P201).
		One of the digital inputs (P121...P124) is set to 10 and another is set to 11...14.	Reconfigure digital inputs
		One of the digital inputs (P121...P124) is set to 11 or 12 and another is set to 13 or 14.	
	PID enabled in Vector Torque mode (P200 = 1 or 2 and P300 = 5)	PID cannot be used in Vector Torque mode	

Troubleshooting and Diagnostics

Fault		Cause	Remedy ⁽¹⁾
F_JF	Remote keypad fault	Remote keypad disconnected	Check remote keypad connections
F_LF	Low DC Bus Voltage fault	Mains voltage too low	Check mains voltage
F_nId	No Motor ID fault	An attempt was made to start the drive in Vector or Enhanced V/Hz mode prior to performing the Motor Auto-calibration	Refer to parameters P300...P399 for Drive Mode setup and calibration.
F_nbF	Module communication fault	Communication failure between drive and Network Module.	Check module connections
F_nF1 ... F_nF9	Network Faults	Refer to the module documentation. for Causes and Remedies.	
F_DF	Output fault: Transistor fault	Output short circuit	Check motor/motor cable
		Acceleration time too short	Increase P104, P125
		Severe motor overload, due to: <ul style="list-style-type: none"> Mechanical problem Drive/motor too small for application 	<ul style="list-style-type: none"> Check machine / system Verify drive/motor are proper size for application
		Boost values too high	Decrease P168, P169
		Excessive capacitive charging current of the motor cable	<ul style="list-style-type: none"> Use shorter motor cables with lower charging current Use low capacitance motor cables Install reactor between motor and drive.
		Failed output transistor	Contact factory technical support
F_DF1	Output fault: Ground fault	Grounded motor phase	Check motor and motor cable
		Excessive capacitive charging current of the motor cable	Use shorter motor cables with lower charging current
F_PF	Motor Overload fault	Excessive motor load for too long	<ul style="list-style-type: none"> Verify proper setting of P108 Verify drive and motor are proper size for application
F_rF	Flying Restart fault	Controller was unable to synchronize with the motor during restart attempt; (P110 = 5 or 6)	Check motor / load
F_SF	Single-Phase fault	A mains phase has been lost	Check mains voltage
F_UF	Start fault	Start command was present when power was applied (P110 = 0 or 2).	<ul style="list-style-type: none"> Must wait at least 2 seconds after power-up to apply Start command Consider alternate starting method (P110).
F_FAU	TB5 (0-10V signal) Threshold fault	0-10V signal (at TB5) drops below the value set in P158.	<ul style="list-style-type: none"> Check signal/signal wire Refer to parameters P157 and P158

(1) The drive can only be restarted if the error message has been reset.

Notes

EDBSV571 • 13441423 • EN • 1.0 • TD16



Lenze Americas Corporation
630 Douglas Street
Uxbridge, MA 01569
USA
1 800 217-9100
marketing@lenzeamericas.com
www.Lenze.com

Service

Lenze AC Tech Corporation
630 Douglas Street
Uxbridge, MA 01569
USA
1 508 278-9100
1 508 278 6620
repair@lenzeamericas.com

Lenze